

EASY205-ASI

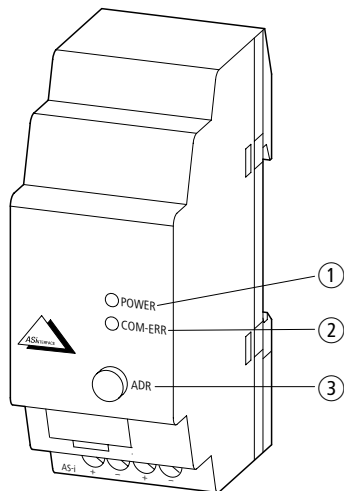

- ① Power $U_{AS-Interface}^{\text{®}}$
- ② COM-ERR Verbindung zum Basisgerät oder AS-Interface[®] Master gestört
- ③ ADR Adressierbus AS-Interface[®]

- ① Power $U_{AS-Interface}^{\text{®}}$
- ② COM-ERR Connection to basic unit or AS-Interface[®] master faulty
- ③ ADR Addressing socket AS-Interface[®]

- ① Power $U_{AS-Interface}^{\text{®}}$
- ② COM-ERR Erreur de communication avec appareil base ou module maître AS-Interface[®]
- ③ ADR Prise d'adressage AS-Interface[®]

- ① Power $U_{AS-Interface}^{\text{®}}$
- ② COM-ERR Collegamento con apparecchio base oppure AS-Interface[®] Master disturbato
- ③ ADR Connettore per indirizzatore AS-Interface[®]



Lebensgefahr durch elektrischen Strom!

Nur Elektrofachkräfte und elektrotechnisch unterwiesene Personen dürfen die im Folgenden beschriebenen Arbeiten ausführen.

Die Stromversorgungsgeräte sind Einbaugeräte. Beachten Sie für die Installation der Geräte die länderspezifischen Vorschriften.

Electric current! Danger to life!

Only skilled or instructed persons may carry out the following operations. The power supply units are mounting devices. The national regulations/specifications must be observed for the installation of the devices.

Tension électrique dangereuse !

Seules les personnes qualifiées et averties doivent exécuter les travaux ci-après. Les blocs d'alimentation sont des appareils faisant partie intégrante d'une installation. Veuillez respecter les normes de mise en œuvre spécifiques aux différents pays.

Tensione elettrica: Pericolo di morte!

Solo persone abilitate e qualificate possono eseguire le operazioni di seguito riportate. Gli alimentatori sono unità per montaggio interno. Per l'installazione degli apparecchi è necessario rispettare le normative specifiche di ciascun paese.

¡Corriente eléctrica! ¡Peligro de muerte!

El trabajo a continuación descrito debe ser realizado por personas cualificadas y advertidas. Las fuentes de alimentación son aparatos de montaje. Para la instalación de los aparatos han de tenerse en cuenta las normativas/especificaciones a nivel local.

- ① Power $U_{AS-Interface}^{\text{®}}$
- ② COM-ERR Perturbación del conexión al aparato base o AS-Interface[®] Master
- ③ ADR Enchufe de direccionamiento AS-Interface[®]

**Standardanschluss – Standard connection – Raccordement standard –
Collegamento standard – Conexión estándar**

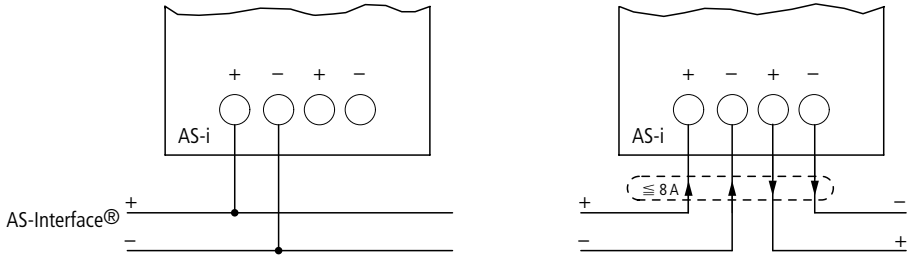

Adressierung – Addressing – Adressage – Indirizzamento – Direccionamiento

AS-Interface®	Profil 7.F
Slave – Esclave	0 ... 31

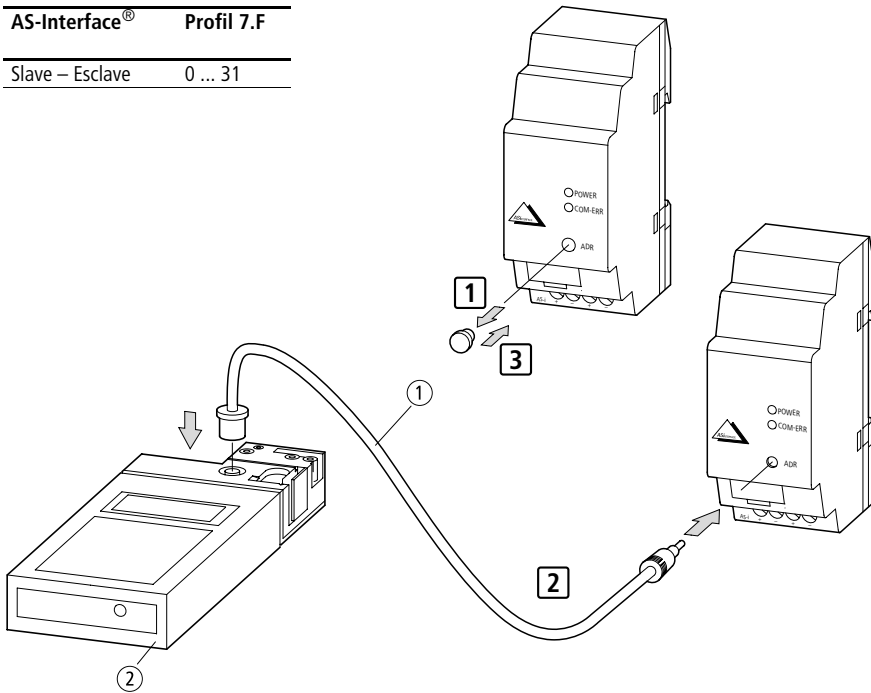

- ① ADL2-ASI
- ② PG2-105-AD...

01/06 AWA2528-1858

Anschluss – Connection – Raccordement – Collegamento – Conexión

AS-Interface®

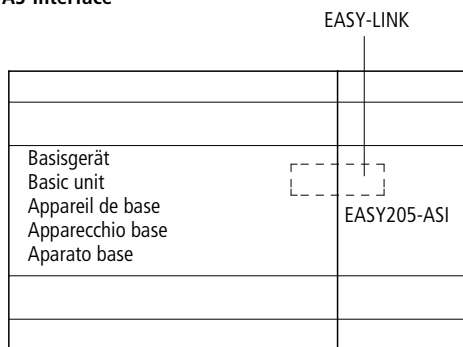

Einbau **1** + **2**, Ausbau **3** + **4**

Fitting **1** + **2**, removing **3** + **4**

Montage **1** + **2**, démontage **3** + **4**

Montaggio **1** + **2**, smontaggio **3** + **4**

Montaje **1** + **2**, desmontaje **3** + **4**



Geräte müssen spannungsfrei sein!

Devices must be de-energized!

Assurer la mise hors tension des appareils !

Gli apparecchi non devono essere alimentati!

¡Los aparatos deben encontrarse libres de tensión!

01/06 AWA2528-1858

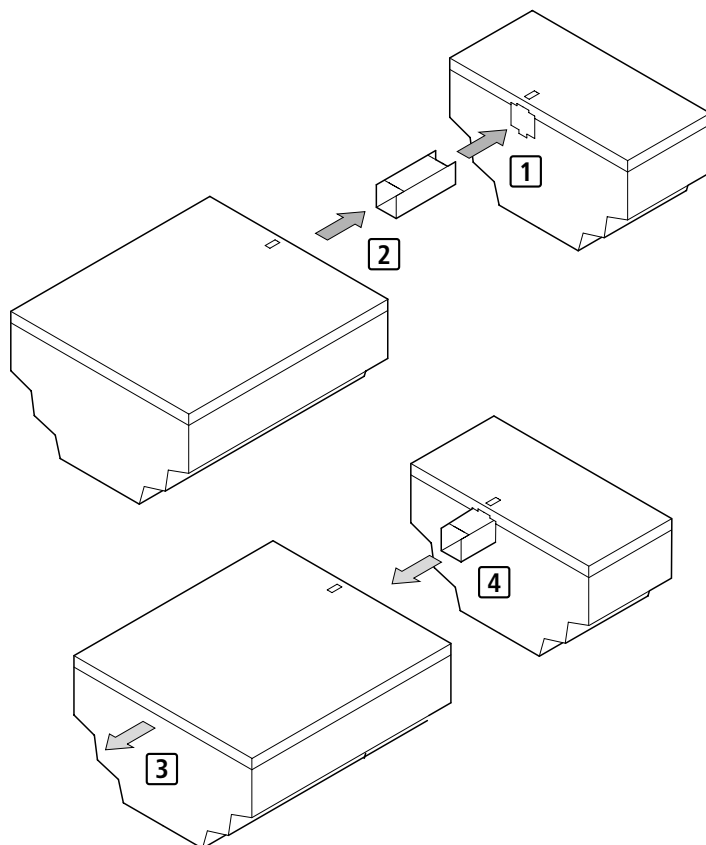

**Datenbelegung – Data assignment – Affectation des données –
Assoziacione segnali – Asignación de datos**

Basisgerät Basic unit Appareil de base Apparecchio base Aparato base	AS-Interface®	Basisgerät Basic unit Appareil de base Apparecchio base Aparato base	AS-Interface®	Basisgerät Basic unit Appareil de base Apparecchio base Aparato base	AS-Interface®
R1	← Q0	R5	← P0	S1	→ I0
2	1	6	1	2	1
3	2	7	2	3	2
4	3	8	3	4	3

**Datenaustauschzeiten – Data exchange times – Durées d'échange de données –
Frequenza scambio dati – Frecuencia de cambio de datos**

EASY205-ASI

Innerhalb eines EASY-Zyklus werden die AS-Interface®-Daten einmal ausgewertet.

AS-Interface® data is scanned once within one EASY cycle.

Les données AS-Interface® sont évaluées une fois par cycle EASY.

Per ogni ciclo di esecuzione di EASY vengono aggiornati i segnali di AS-Interface®.

Dentro de un ciclo EASY, los datos AS-Interface® se analizan una vez.

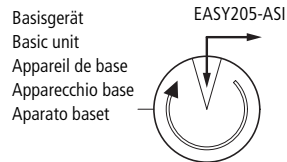

01/06 AWA2528-1858

**Kommunikationsfehler AS-Interface®-Master
Communication error AS-Interface® master
Erreur de communication Maître AS-Interface®
Errore di comunicazione AS-Interface® Master
Error de comunicación AS-Interface®-Master**

- Adressierleitung gesteckt
- EASY-LINK defekt
- Basisgerät wird nicht erkannt
- Basisgerät in der Betriebsart „STOP“
- Leitung defekt, nicht angeschlossen
- Slaveadresse = 0
- Cavo per indirizzamento inserito
- Errore in EASY-LINK
- Apparecchio base non viene riconosciuto
- Apparecchio base in modalità “STOP”
- Cavo difettoso, non collegato
- Indirizzo slave = 0
- Addressing cable inserted
- EASY-LINK faulty
- Basic unit is not detected
- Basic unit in “STOP” mode
- Cable faulty, not connected
- Slave address = 0
- Conducto de direccionamiento conectado
- El EASY-LINK está defectuoso
- No reconoce el aparato base
- Aparato base en modo “STOP”
- Conducto defectuoso, no conectado
- Dirección slave = 0
- Câble d’adressage enfiché
- EASY-LINK défectueux
- Appareil base n’est pas reconnu
- Appareil base en mode « STOP »
- Câble défectueux, non raccordé
- Adresse esclave = 0

Einklappseite: 17 mm Beschnitt

Fehlerauswertung EASY – Fault detection EASY – Analyse du défaut EASY – Segnale di anomalia EASY – Evaluación de error EASY

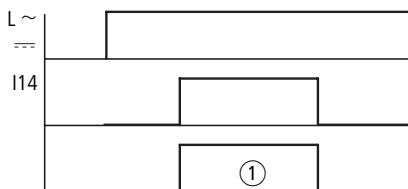

Basisgerät – Basic unit – Appareil de base –
Apparecchio base – Aparato base

EASY205-ASI

- | | |
|---|--|
| <p>① AS-Interface® nicht angeschlossen oder nicht betriebsbereit</p> <ul style="list-style-type: none"> – Kabelbruch/Kabel falsch angeschlossen – AS-Interface® Netzwerkausfall – AS-Interface®-Master nicht in Betrieb – Slaveadresse = 0 <p>① AS-Interface® not connected or not ready for operation</p> <ul style="list-style-type: none"> – Cable break/Cable incorrectly connected – AS-Interface® network failure – AS-Interface® master not in operation – Slave address = 0 <p>① AS-Interface® non raccordé ou non opérationnel</p> <ul style="list-style-type: none"> – Rupture du câble/câble mal raccordé – Panne de secteur AS-Interface® – Maître AS-Interface® non sous tension – Adresse esclave = 0 | <p>① AS-Interface® non collegato o non funzionante</p> <ul style="list-style-type: none"> – rottura cavo/cavo collegato in modo errato – AS-Interface® Errore di rete – AS-Interface® Master non in esecuzione – Indirizzo slave = 0 <p>① El AS-Interface® no está conectado o no está preparado para el servicio</p> <ul style="list-style-type: none"> – Rotura de cable/cable mal conectado – Avería de la red AS-Interface® – AS-Interface®-Master fuera de servicio – Dirección slave = 0 |
|---|--|

LED Signalisierung – LED Signals – Signalisation DEL – Segnalazioni a – Señalización por LED

EASY205-ASI

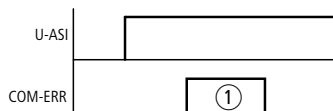
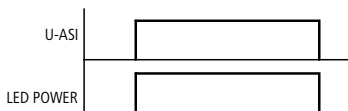

- | | |
|--|--|
| <p>① – EASY-LINK defekt</p> <ul style="list-style-type: none"> – Basisgerät wird nicht erkannt – Basisgerät in der Betriebsart „STOP“ – Slaveadresse = 0 – AS-Interface®-Master nicht in Betrieb <p>① – EASY-LINK faulty</p> <ul style="list-style-type: none"> – Basic unit is not detected – Basic unit in “STOP” mode – Slave address = 0 – AS-Interface® master not in operation <p>① – EASY-LINK défectueux</p> <ul style="list-style-type: none"> – Appareil base n’est pas reconnu – Appareil base en mode « STOP » – Adresse esclave = 0 – Maître AS-Interface® non sous tension | <p>① – Errore in EASY-LINK</p> <ul style="list-style-type: none"> – Apparecchio base non viene riconosciuto – Apparecchio base in modalità “STOP” – Indirizzo slave = 0 – AS-Interface® Master non in esecuzione <p>① – El EASY-LINK está defectuoso</p> <ul style="list-style-type: none"> – No reconoce el aparato base – Aparato base en modo “STOP” – Dirección slave = 0 – AS-Interface® Master fuera de servicio |
|--|--|

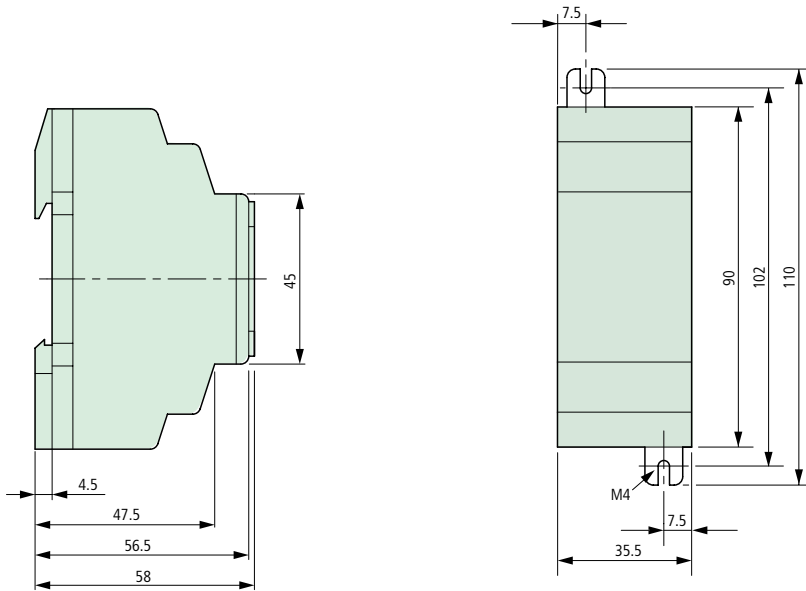

01/06 AWA2528-1858

HAZARDOUS LOCATION – CSA (Canadian Standards Association) Certification

This equipment is suitable for use in CLASS I, DIVISION 2, GROUPS A, B, C AND D

WARNING: "EXPLOSION HAZARD – DO NOT DISCONNECT WHILE CIRCUIT IS LIVE UNLESS AREA IS KNOWN TO BE NON-HAZARDOUS"

EMPLACEMENTS DANGEREUX – Certification CSA (Canadian Standards Association)

Cet équipement est acceptable pour utilisation dans les EMBLEMES DANGEREUX DE CLASSE I, DIVISION 2, GROUPES A, B, C ET D

AVERTISSEMENT : « RISQUE D'EXPLOSION. NE PAS DÉBRANCHER TANT QUE LE CIRCUIT EST SOUS TENSION, A MOINS QU'IL NE S'AGISSE D'UN EMBLEMES NON DANGEREUX »