

EASY412-AC-... EASY412-DC-... EASY412-DA-...

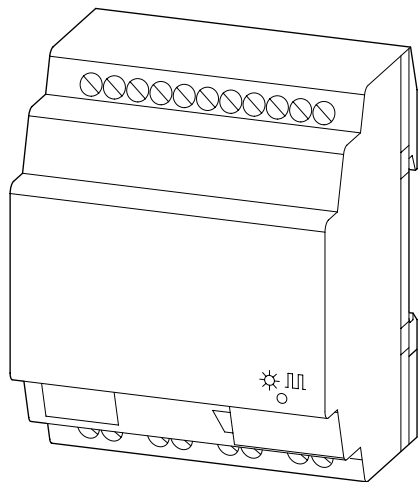
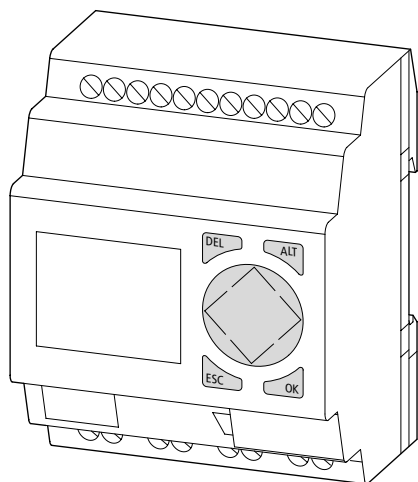
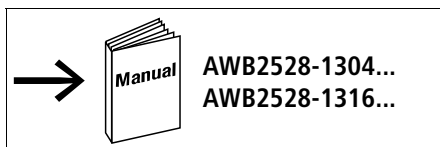

Lebensgefahr durch elektrischen Strom!

Nur Elektrofachkräfte und elektrotechnisch unterwiesene Personen dürfen die im Folgenden beschriebenen Arbeiten ausführen.

Die Stromversorgungsgeräte sind Einbaugeräte. Beachten Sie für die Installation der Geräte die länderspezifischen Vorschriften.

Electric current! Danger to life!

Only skilled or instructed persons may carry out the following operations. The power supply units are mounting devices. The national regulations/specifications must be observed for the installation of the devices.

Tension électrique dangereuse !

Seules les personnes qualifiées et averties doivent exécuter les travaux ci-après. Les blocs d'alimentation sont des appareils faisant partie intégrante d'une installation. Veuillez respecter les normes de mise en œuvre spécifiques aux différents pays.

Tensione elettrica: Pericolo di morte!

Solo persone abilitate e qualificate possono eseguire le operazioni di seguito riportate. Gli alimentatori sono unità per montaggio interno. Per l'installazione degli apparecchi è necessario rispettare le normative specifiche di ciascun paese.

¡Corriente eléctrica! ¡Peligro de muerte!

El trabajo a continuación descrito debe ser realizado por personas cualificadas y advertidas. Las fuentes de alimentación son aparatos de montaje. Para la instalación de los aparatos han de tenerse en cuenta las normativas/especificaciones a nivel local.

Frontansicht

Front view

Face avant

Vista frontale

Vista de frente

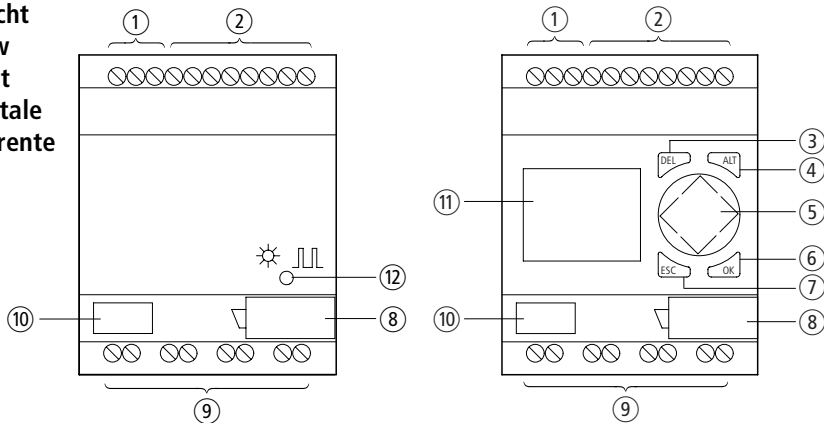

- | | |
|--|--|
| <p>① Spannungsversorgung
EASY412-DC-...24 V DC
EASY412-DA-...12 V DC
EASY412-AC-...90 bis 264 V AC 50/60 Hz</p> <p>② 8 Eingänge
EASY412-DC-...24 V DC,
EASY412-DA-...12 V DC
(2 auch als Analog-Eingänge 0 bis 10 V nutzbar)
EASY412-AC-...0 bis 264 V AC</p> <p>③ DEL-Taste
Löschen von Kontakten/Relais/
Verbindungen/leerem Strompfad</p> <p>④ ALT-Taste
Verbindungen zeichnen
Umschalter: Kontakt = Schließer oder Öffner
Strompfad einfügen</p> <p>⑤ Cursortasten: rechts, links, oben, unten
Kontakte, Relais, Nummer wählen
P-Taste an: Eingang P1 -> Cursor links
Eingang P2 -> Cursor oben
Eingang P3 -> Cursor rechts
Eingang P4 -> Cursor unten</p> <p>⑥ OK-Taste
Menü weiterschalten, Aktion übernehmen</p> <p>⑦ ESC-Taste
Ein Menü zurück
Menü, Parameter Funktionsrelais verlassen
Verlassen ohne Speichern</p> <p>⑧ Schnittstelle (mit Abdeckung)
Steckplatz für Speicherkarte
Buchse für PC-Schnittstellenkabel</p> <p>⑨ Kontakte Ausgänge</p> <p>⑩ Geräteerkennungsschild</p> <p>⑪ LCD
Zustandsanzeige der Ein-/Ausgänge
Betriebszustände
Schaltplan
Anzeige der Uhr (nur bei Typen mit „C“)</p> <p>⑫ Power/Run-LED</p> | <p>① Voltage supply
EASY412-DC-...24 V DC
EASY412-DA-...12 V DC
EASY412-AC-...90 to 264 V AC 50/60 Hz</p> <p>② 8 Inputs
EASY412-DC-...24 V DC,
EASY412-DA-...12 V DC
(2 can also be used as 0 to 10 V analog inputs)
EASY412-AC-...0 to 26/4 V AC</p> <p>③ DEL button
Delete contacts/relays/connections/
empty current path</p> <p>④ ALT button
Draw connection
Toggle between make or break contact
Insert current path</p> <p>⑤ Cursor buttons: right, left, up, down
Select contacts, relays, numbers
P button on: Input P1 -> Cursor left
Input P2 -> Cursor up
Input P3 -> Cursor right
Input P4 -> Cursor down</p> <p>⑥ OK button
Enter menu, accept action</p> <p>⑦ ESC button
One menu back
Exit function relay parameter menu without saving</p> <p>⑧ Interface (with cover)
Slot for memory card
Socket for PC interface cable</p> <p>⑨ Contacts, outputs</p> <p>⑩ Device label</p> <p>⑪ LCD
I/O status display
Operating states
Circuit diagram
Display of clock (only with types with "C")</p> <p>⑫ Power/Run LED</p> |
|--|--|

- | | |
|---|---|
| <p>① Alimentation
EASY412-DC-...24 V CC
EASY412-DA-...12 V CC
EASY412-AC-...90 à 264 V CA 50/60 Hz</p> <p>② 8 Entrées
EASY412-DC-...24 V CC,
EASY412-DA-...12 V CC
(dont 2 utilisables comme entrées analogiques 0 à 10 V)
EASY412-AC-...0 à 264 V CA</p> <p>③ Touche DEL
Effacement des objets (contacts, relais, liaison, circuits de courant vides) au niveau de la position du curseur</p> <p>④ Touche ALT
Dessiner les liaisons
Inverseur : contact = contact F ou contact O
Insérer circuit de courant</p> <p>⑤ Touches de direction : droite, gauche, haut, bas
Sélectionner opérandes et indices (contacts, relais, numéro)
Affectation des touches entrée P :
entrée P1 -> curseur gauche
entrée P2 -> curseur haut
entrée P3 -> curseur droite
entrée P4 -> curseur bas</p> <p>⑥ Touche OK
Niveau menu, exécuter la fonction</p> <p>⑦ Touche ESC
Retour au menu précédent
Quitter le niveau « Entrée du programme »
Quitter sans enregistrer</p> <p>⑧ Interface (avec capot)
Emplacement pour carte mémoire
Connecteur femelle pour câble d'interface PC
Contacts de sortie</p> <p>⑨ Etiquette de repérage de l'appareil</p> <p>⑩ LCD</p> <p>⑪ Tension d'alimentation/DEL RUN</p> | <p>① Tensione di alimentazione
EASY412-DC-...24 V DC
EASY412-DA-...12 V DC
EASY412-AC-...90 a 264 V AC 50/60 HZ</p> <p>② 8 Ingressi
EASY412-DC-...24 V DC,
EASY412-DA-...12 V DC
(2 utilizzabili anche come ingressi analogici 0 a 10 V)
EASY412-AC-...0 a 264 V AC</p> <p>③ Tasto DEL
Cancellazione di contatti, relè, collegamenti, circuiti di corrente vuoti</p> <p>④ Tasto ALT
Disegno dei collegamenti
Commutatore: contatto = chiusura/apertura
Inserisci/cancella riga, circuito di corrente</p> <p>⑤ Tasti cursore, destra, sinistra, su, giù
Selezione contatti, relè, numeri
Tasto P a: lato P1 -> cursore a sinistra
lato P2 -> cursore su
lato P3 -> cursore a destra
lato P4 -> cursore giù</p> <p>⑥ Tasto OK
Menu successivo, conferma azione</p> <p>⑦ Tasto ESC
Menu precedente
Esci dal menu, parametro relè di funzione
Esci senza salvare</p> <p>⑧ Interfaccia (con copertura)
Posizione di inserimento per la scheda di memoria
Connettore femmina per cavo di interfaccia PC</p> <p>⑨ Uscite contatti</p> <p>⑩ Targhetta per il nome dell'apparecchio</p> <p>⑪ LCD
Visualizzazione di stato degli ingressi/uscite
Stati di funzionamento
Schema a contatti
Visualizzazione dell'ora (solo per i tipi con "C")</p> <p>⑫ LED Power/Run</p> |
|---|---|

- | | |
|---|--|
| <p>① Tensión de alimentación
EASY412-DC-...24 V DC
EASY412-DA-...12 V DC
EASY412-AC-...90 a 264 V AC 50/60 Hz</p> <p>② 8 Entradas
EASY412-DC-...24 V DC,
EASY412-DA-...12 V DC
(2 también pueden utilizarse como entradas analógicas de 0 a 10 V)
EASY412-AC-...0 a 264 V AC</p> <p>③ Tecla DEL
Borrar contactos/relés/conexiones/circuito de corriente en vacío</p> <p>④ Tecla ALT
Diseñar conexiones
Accionamiento del interruptor basculante (toggle) entre contacto de apertura o de cierre
Insertar circuito de corriente</p> <p>⑤ Teclas de cursor: derecha, izquierda, arriba, abajo.
Selección de contactos, relés, números
Tecla P sobre: Entrada P1 -> Cursor izquierda
Entrada P2 -> Cursor arriba
Entrada P3 -> Cursor derecha
Entrada P4 -> Cursor abajo</p> | <p>⑥ Tecla OK
Entrar menú, aceptar acción</p> <p>⑦ Tecla ESC
Un menú hacia atrás
Salir del menú de parámetros del módulo lógico
Salir sin archivar</p> <p>⑧ Interface (con tapa)
Slot para tarjeta de memoria
Hembrilla para cable de interface a PC</p> <p>⑨ Contactos, salidas</p> <p>⑩ Etiqueta de características del aparato</p> <p>⑪ LCD
Visualizador de estado ABIERTO/CERRADO
Estados operativos
Esquema de circuitos
Display del reloj (sólo con tipos con "C")</p> <p>⑫ Cierre/LED de funcionamiento</p> |
|---|--|

Standardanschluss, Eingänge – Standard connection, inputs – Raccordement standard, entrées – Collegamento standard, ingressi – Conexión estándar, entradas

EASY412-DC-...

EASY412-DA-...

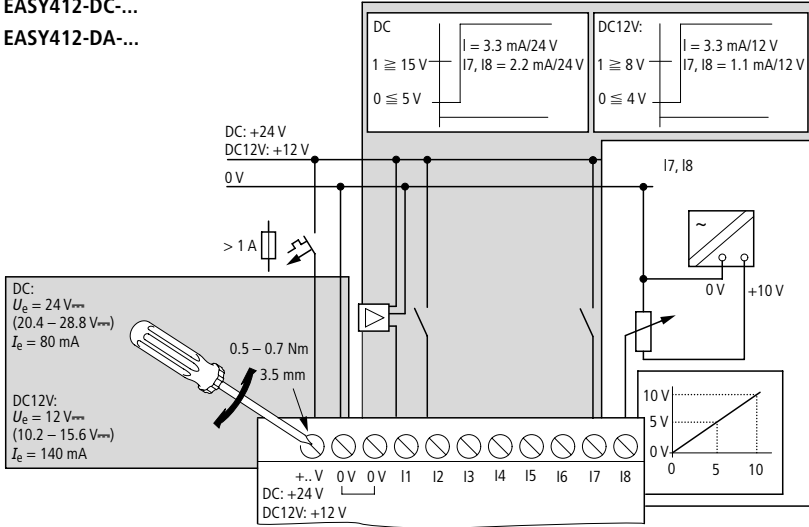

EASY412-AC-...

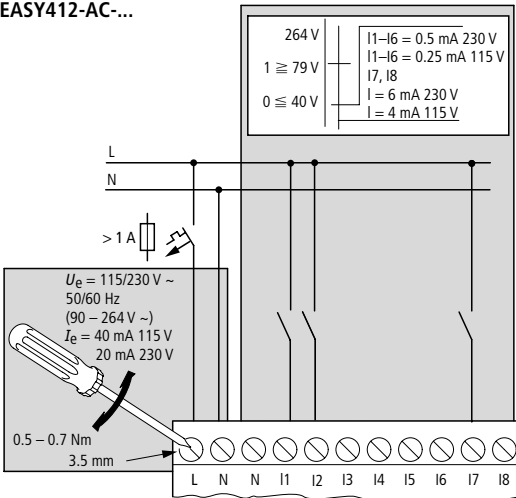

04/02 AWA2528-1654

Ausgänge – Outputs – Sorties – Uscite – Salidas

EASY412-...-R..

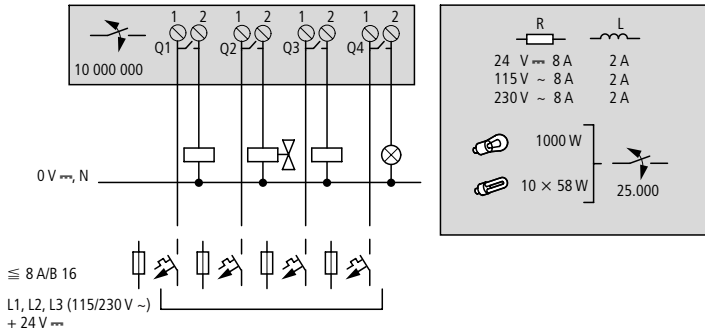

EASY412-DC-T..

04/02 AWA2528-1654

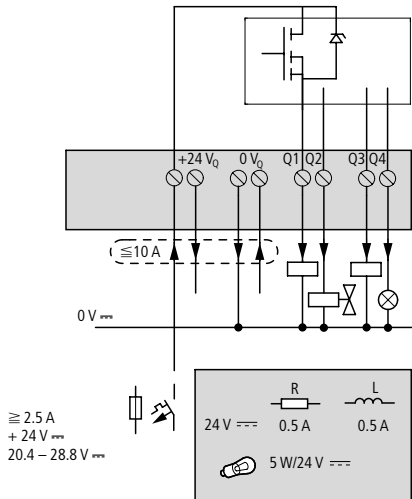

Schutzbeschaltung Protective circuit Circuit de protection Circuito di protezione Circuito supresor

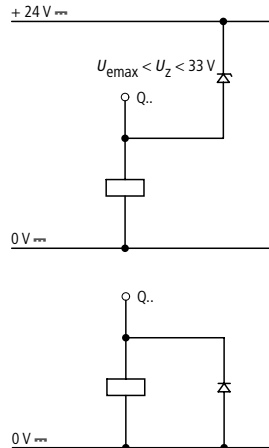

Sprachauswahl bei erster Inbetriebnahme

Language selection for commissioning

Choix de la langue en cas de première mise en service

Selezione della lingua alla prima messa in servizio

Selección de lenguaje en la puesta en marcha

D, GB, F, E, I

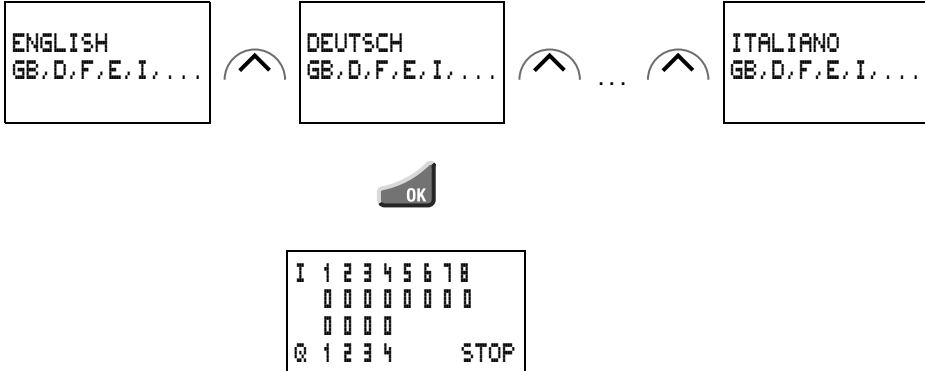

Relais, Kontakte – Relays, contacts – Relais, contacts – Relè, contatti – Relés, contactos

	I	\bar{I}	1-0, 1b
Q	Q	\bar{Q}	1-4
M	M	\bar{M}	1-1b
	A	\bar{A}	1-8
	Ø	$\bar{Ø}$	1-4
C	C	\bar{C}	1-8
T	T	\bar{T}	1-8
	P	\bar{P}	1-4

04/02 AWA2528-1654

Temperaturbereich:

Temperature range:

Plage de température :

Campo temperatura:

Margen de temperatura:

-25...+55 °C

- LCD-Anzeige im Bereich 0 bis 55 °C lesbar
- Betauung des Gerätes unbedingt verhindern!
- LCD display legible in range 0 to 55 °C
- On no account allow condensation to form on the device!
- Afficheur à cristaux liquides lisible dans la plage 0 à 55 °C
- Eviter impérativement toute condensation sur l'appareil !
- Visualizzatore LCD leggibile a una temperatura compresa tra 0 a 55 °C
- Impedire assolutamente la formazione di condensa sull'apparecchio!
- El visualizador LCD es legible dentro de un margen entre 0 – 55 °C
- No debe producirse condensación en el aparato!

Kurzschlussauswertung

Short-circuit detection

Analyse du court-circuit

Interpretazione cortocircuito

Detección de cortocircuitos

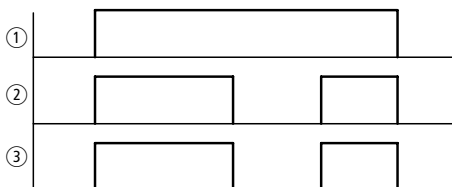

①

Spannungsversorgung der Ausgänge
Power supply of the outputs
Alimentation en tension des sorties
Alimentazione delle uscite
Alimentación de tensión de las salidas

②

Kurzschluss, Überlast, Übertemperatur
Short-circuit, overload, overtemperature
Court-circuit, surcharge, échauffement
Cortocircuito, sovraccarico, sovratemperatura
Cortocircuito, sobrecarga, sobretemperatura

③

Fehlererkennung I16
Fault detection I16
Détection de défauts I16
Riconoscimento errori I16
Detección de fallos I16

04/02_AWA2528-1654

Remanenz – Retention – Rémanence – Rimanenza – Retención

(EASY412-DC-..., EASY412-DA-...)

S, R, J, M13, M14, M15, M16, T8, C8:

Remanent bei Menüanzeige REMANENZ AUS

Retentive with menu display RETENT. OFF (retention off)

Rémanents lors de l'affichage REMANENT NON (rémanence désactivée)

Rimanenti nella visualizzazione menu RET. PARO (senza rimanenza)

Remanentes con visualización RIMANEN. OFF (retención desactivada)

```
DEBOUNCE ON
P OFF
MODE: RUN
RETENT. OFF
```

```
I ENTPR. EIN
P TASTEN AUS
ANLAUF RUN
REMANENZ AUS
```

```
TEMPO EN. OUI
P BOUTON NON
MODE RUN
REMANENT NON
```

```
ENTR. RETR. MA
P PARADA
MOD: RUN
RET: PARO
```

```
RIT. INPUT ON
P TASTO OFF
MODAL. RUN
RIMANEN. OFF
```

Anlauf „RUN“
 “RUN” mode
 Mode « RUN »
 Avviamento con “RUN”
 Modo “RUN”

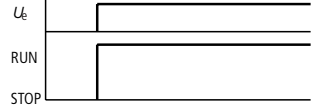
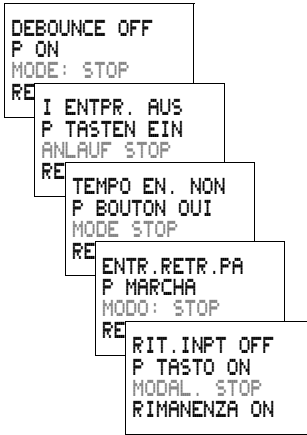

Anlauf im „STOP“
 “STOP” mode
 Mode « STOP »
 Avviamento con “STOP”
 Modo “STOP”

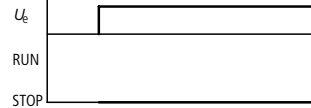
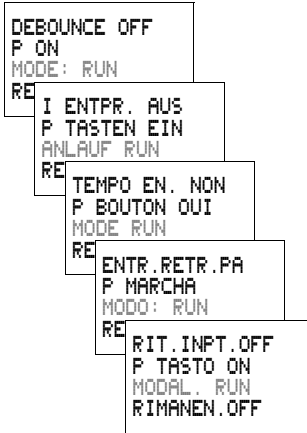

04/02_AWA2528-1654

Systemmenü
 System menu
 Menu spécial
 Menù speciale
 Menú especial

PASSWORD... SVSTEM GB D F E I	→	DEBOUNCE OFF P ON MODE: STOP RETENTION ON	DEBOUNCE ON P OFF MODE: RUN RETENT.OFF
-------------------------------------	---	--	---

PASSWORT... SVSTEM GB D F E I	→	I ENTRP. AUS P TASTEN EIN ANLAUF STOP REMANENZ EIN	I ENTRP. EIN P TASTEN AUS ANLAUF RUN REMANENZ AUS
-------------------------------------	---	---	--

MOT DE PASSE SVSTEM GB D F E I	→	TEMPO EN.NON P BOUTON OUI MODE STOP REMANENT OUI	TEMPO EN.OUI P BOUTON NON MODE RUN REMANENT NON
--------------------------------------	---	---	--

PASSWORD... SVSTEM GB D F E I	→	ENTR.RETR.PA P MARCHA MODO: STOP RET. MARCHA	ENTR.RETR.MA P PARADA MODO: RUN RET. PARO
-------------------------------------	---	---	--

PASSWORD... SVSTEM GB D F E I	→	RIT.INPT.OFF P TASTO ON MODAL. STOP RIMANENZA ON	RIT.INPUT ON P TASTO OFF MODAL. RUN RIMANEN.OFF
-------------------------------------	---	---	--

04/02 AWA2528-1654

Schnittstelle EASY-PC-CAB ①/Speichermodul EASY-M-8K ②

EASY-PC-CAB interface ①/EASY-M-8K memory card ②

Interface EASY-PC-CAB ①/carte mémoire EASY-M-8K ②

Interfaccia EASY-PC-CAB ①/scheda di memoria EASY-M-8K ②

Interface EASY-PC-CAB ①/tarjeta de memoria EASY-M-8K ②

1

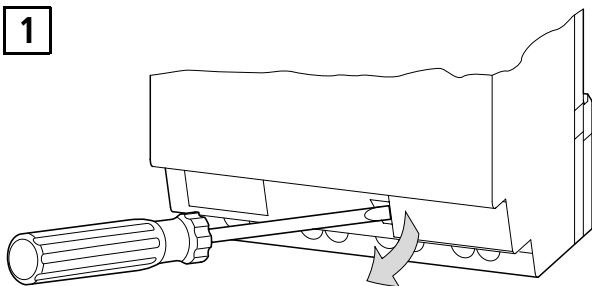

2

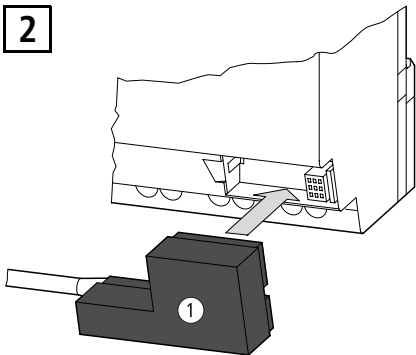

3

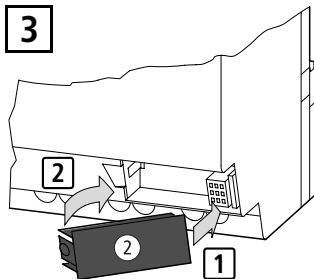

04/02_AWA2528-1654



EASY412-AC...

Schnittstelle bei Betrieb mit 115/230 V geschlossen halten!

When operating with 115/230 V keep interface closed!

En cas de fonctionnement sous 115/230 V, s'assurer que l'emplacement destiné à la cartouche mémoire et au câble PC soit obturé afin d'éviter tout danger !

Tenere chiusa l'interfaccia per il funzionamento con 115/230 V!

Mantener interface cerrado con accionamiento a 115/230 V!

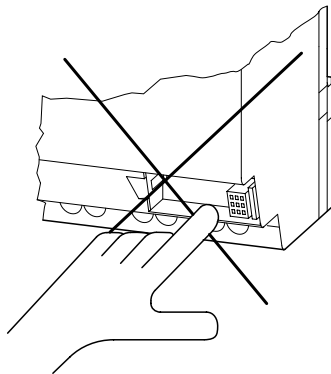

Montage – Fitting – Montaggio – Montaje

auf 35-mm-Hutschiene
on 35 mm top-hat rail
sur profilé-support 35 mm
su guida DIN 35 mm
sobre guía semétrica de 35 mm

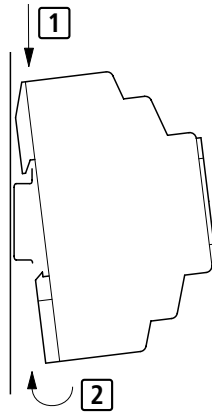

auf Montageplatte (waagrecht)
on mounting plate (horizontal)
sur plaque de montage (horizontal)
su piastra di montaggio (orizzontale)
sobre placa de montaje (horizontal)

ZB4-101-GF1

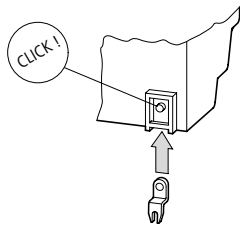

04/02 AWA2528-1654

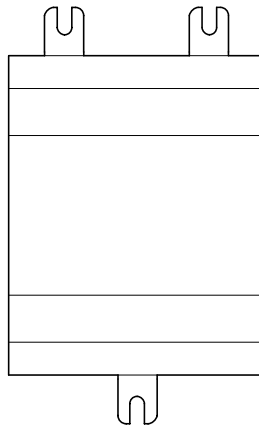

Einbaulage – Mounting position – Position de montage – Posizione di montaggio – Posición de montaje

mit Hutschiene (waagrecht und senkrecht)
with top-hat rail (horizontal and vertical)
sur profilé chapeau (horizontale et verticale)
su guida DIN (orizzontale e verticale)
sobre carril (horizontal y vertical)

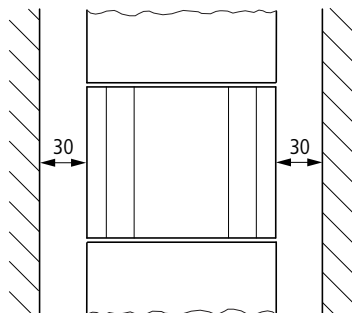
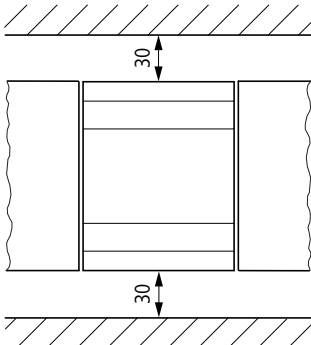

Abmessungen – Dimensions – Dimensioni – Dimensiones [mm]

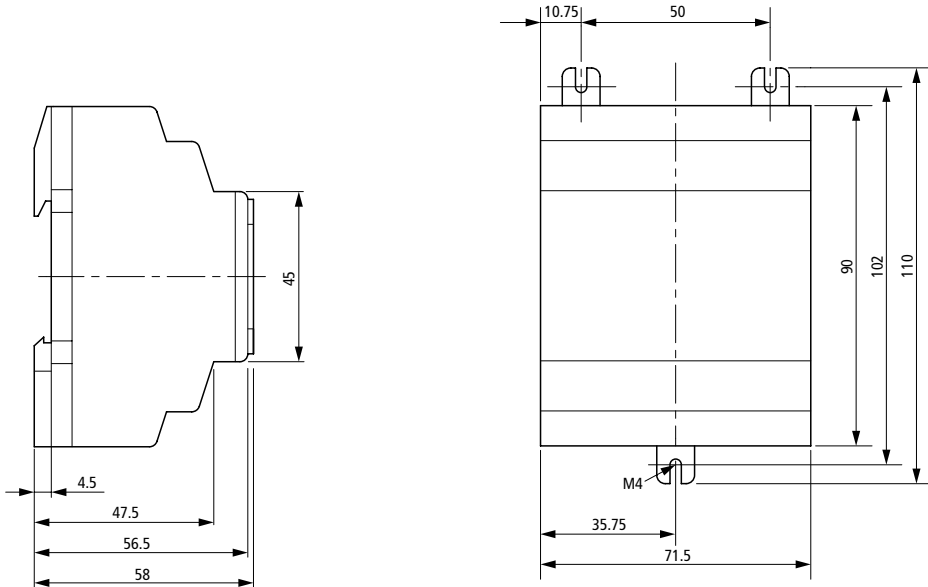

04/02 AWA2528-1654

HAZARDOUS LOCATION – CSA (Canadian Standards Association) Certification

This equipment is suitable for use in CLASS I, DIVISION 2, GROUPS A, B, C AND D

WARNING: "EXPLOSION HAZARD – DO NOT DISCONNECT WHILE CIRCUIT IS LIVE UNLESS AREA IS KNOWN TO BE NON-HAZARDOUS"

EMPLACEMENTS DANGEREUX – Certification CSA (Canadian Standards Association)

Cet équipement est acceptable pour utilisation dans les EMBLEMES DANGEREUX DE CLASSE I, DIVISION 2, GROUPES A, B, C ET D

AVERTISSEMENT : « RISQUE D'EXPLOSION. NE PAS DÉBRANCHER TANT QUE LE CIRCUIT EST SOUS TENSION, A MOINS QU'IL NE S'AGISSE D'UN EMBLEMES NON DANGEREUX »