

## PS 4-100

01/98 AWA 27-1260

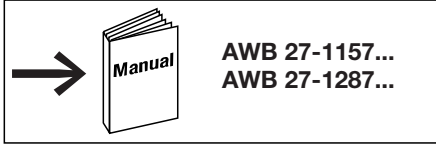

Abmessungen

Dimensions

Dimensioni

Dimensiones

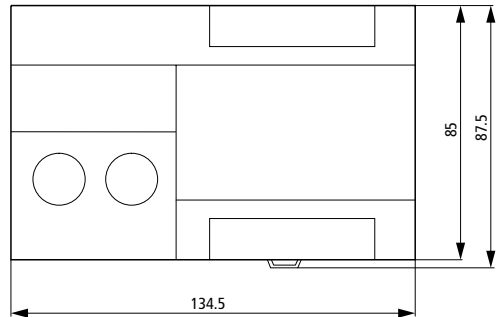
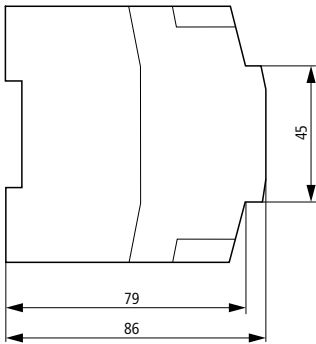

UL/CSA

Model/No	Power Supply	# of channels and Input Rating	# of channels and Output Rating
PS 4-101-DD1	24 V DC 0.2 A	8 digital 24 V DC	6 digital 24 V DC, 0.5 A 24 V DC, 0.5 A p.d.*
PS 4-101-DR1	240 AC 0.1 A 50/60 Hz	8 digital 24 V DC	6 digital, 2 A 240 V AC 50/60 Hz 24 V AC, 1.5 A p.d.* 24 V DC, 2 A

\* p. d. Pilot Duty/Maximum operating temperature 55° C/  
Tightening torque 0.6 Nm/AWG 12-28

Frontansicht

Front view

Face avant

Vista frontale

Vista de frente

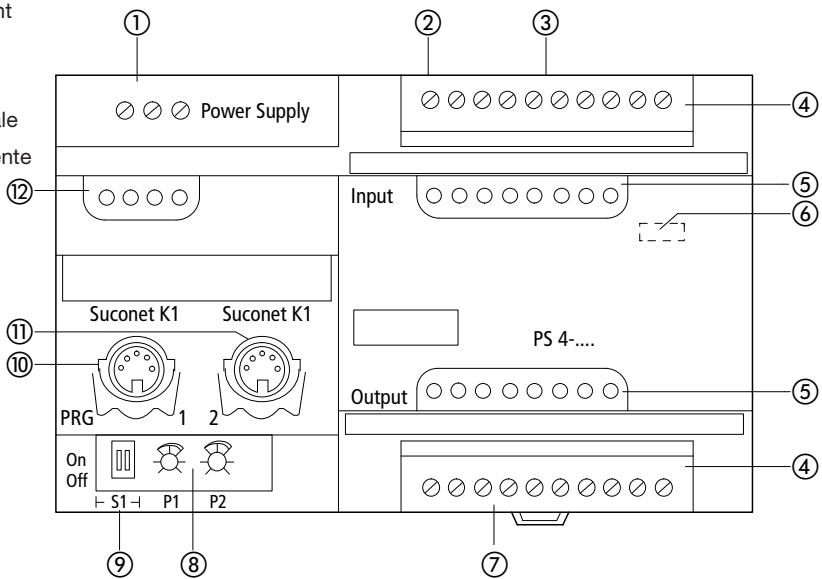

(D)

- ① Stromversorgung  
PS 4-101-DD1: 24 V DC  
PS 4-111-DR1/DR5: 115 bis 230 V AC
- ② Eingang Schneller Zähler (3 kHz)
- ③ 8 Digital-Eingänge 24 V DC
- ④ Steckbare Schraubklemme
- ⑤ Statusanzeige
- ⑥ Schalter Master/Slave-Modus (S2)
- ⑦ PS 4-101-DD1: 6 Digital-Ausgänge  
PS 4-111-DR1/DR5: 6 Relaisausgänge
- ⑧ Sollwertgeber
- ⑨ Schalter S1 für Busabschluß-  
widerstände
- ⑩ Suconet-K1-Schnittstelle und  
PRG-Schnittstelle
- ⑪ Suconet-K1-Schnittstelle
- ⑫ Statusanzeige

(GB)

- ① Power supply  
PS 4-101-DD1: 24 V DC  
PS 4-111-DR1/DR5: 115 to 230 V AC
- ② Input high-speed counter (3 kHz)
- ③ 8 24 V DC digital inputs
- ④ Plug-in screw terminals
- ⑤ LED status display
- ⑥ Switch master/slave mode (S2)
- ⑦ PS 4-101-DD1: 6 digital outputs;  
PS 4-111-DR1/DR5: 6 Relay outputs,
- ⑧ Setpoint potentiometer P1, P2
- ⑨ S1 switch for bus terminating  
resistors
- ⑩ Suconet K1 interface and PRG  
terminal
- ⑪ Suconet K1 interface
- ⑫ LED status display

(F)

- ① Alimentation  
PS 4-101-DD1 : 24 V CC  
PS 4-111-DR1/DR5 : 115 à 230 V CA
- ② Entrée compteur rapide (3 kHz)
- ③ 8 entrées digitales 24 V CC
- ④ Bornier à vis enfichable
- ⑤ Afficheur d'état DEL entrées
- ⑥ Commutateur de mode maître/esclave (S2)

- ⑦ PS 4-101-DD1 : 6 sorties digitales  
PS 4-111-DR1/DR5 : 6 sorties relais
- ⑧ Module d'entrée de consignes
- ⑨ S1 interrupteur pour résistance de  
termination de bus
- ⑩ Liaison Suconet K1 et raccordement  
PRG
- ⑪ Liaison Suconet K1
- ⑫ Afficheur d'état DEL

I

- ① Alimentazione  
PS 4-101-DD1: 24 V DC  
PS 4-111-DR1/DR5: 115 a 230 V AC
- ② Ingresso contattore veloce 3 kHz
- ③ 8 ingressi digitali 24 V DC
- ④ Morsetto a vite sfilabile
- ⑤ Visualizzazione di stato a LED degli ingressi
- ⑥ Interruttore master/slave modo (S2)
- ⑦ PS 4-101-DD1: 6 uscite digitali  
PS 4-111-DR1/DR5: 6 uscite relé
- ⑧ Potenzziometro P1, P2
- ⑨ Interruttore S1 resistenze di terminazione bus
- ⑩ Interfaccia Suconet K1 e collegamento a PRG
- ⑪ Interfaccia Suconet K1
- ⑫ Visualizzazione a LED

E

- ① Alimentación  
PS 4-101-DD1: 24 V DC  
PS 4-111-DR1/DR5: 115 a 230 V AC
- ② Entrada de contador rapido 3 kHz
- ③ 8 entradas digitales 24 V DC
- ④ Terminal roscado enchufable
- ⑤ LED visualización entradas
- ⑥ Interruptor maestro/slave modo (S2)
- ⑦ PS 4-101-DD1: 6 salidas digitales  
PS 4-111-DR1/DR5: 6 salidas por relés
- ⑧ Encoder
- ⑨ Interruptor S1 para bus resistencias terminales
- ⑩ Interface Suconet K1 y conexión PRG
- ⑪ Interface Suconet K1
- ⑫ LED visualización

Schirmerdung für Hutschiene ①/Montageplatte ②

Earthing the screen for top-hat rail ①/mounting plate ②

Mise à la terre du blindage pour profilé-support ①/plaque de montage ②

Collegamento a la terra dello schermo per guida ①/piastra di montaggio ②

Conexión a tierra de pantalla para guía simétrica ①/placa de montaje ②

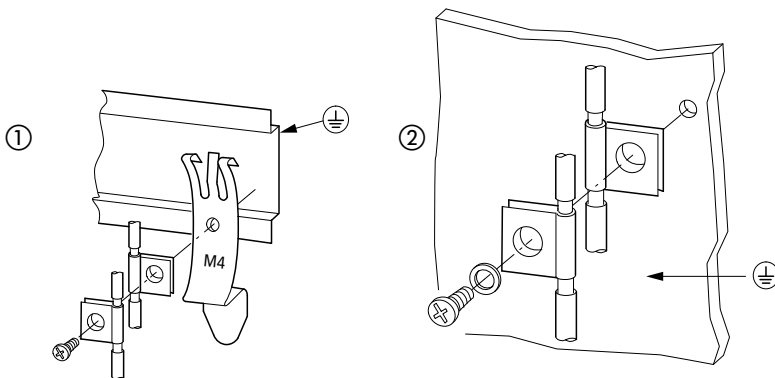
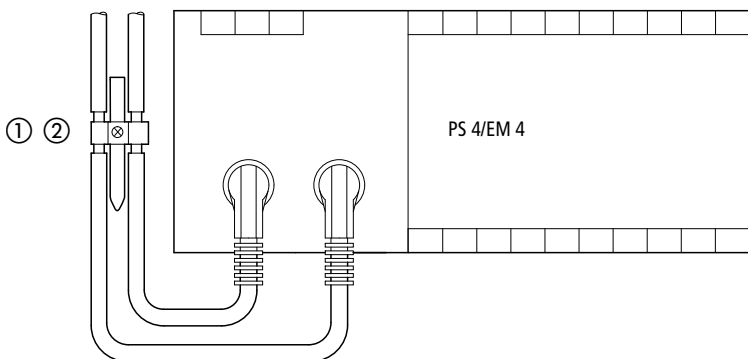

Anschlüsse  
 Connections  
 Raccordements  
 Collegamenti  
 Conexiones

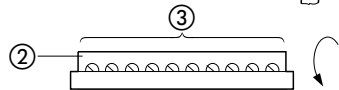
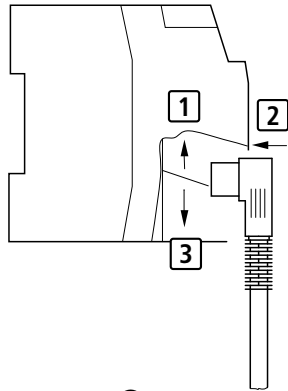
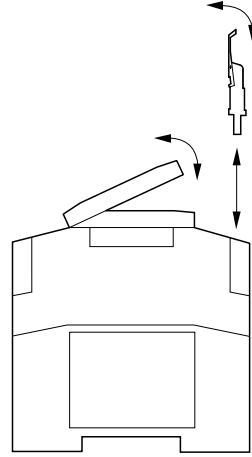
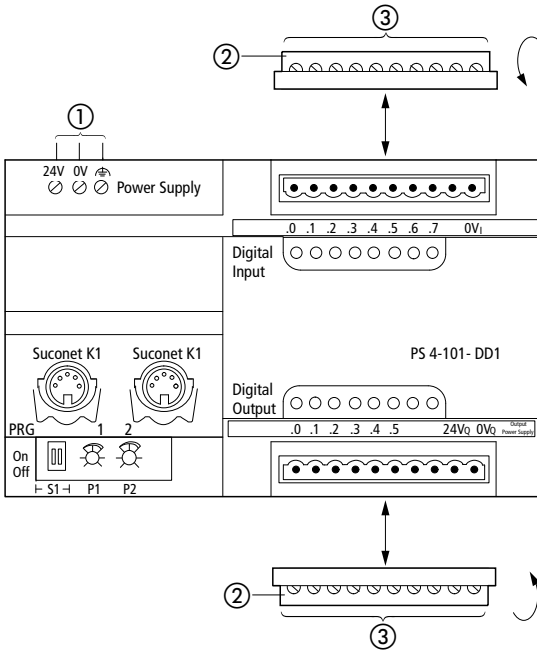

D

- ① Schraubklemmen  
Anschlußquerschnitt  
– feindrätig mit Aderendhülse  
0,22 bis 2,5 mm<sup>2</sup>  
– eindrätig 0,22 bis 2,5 mm<sup>2</sup>
- ② steckbare Schraubklemme
- ③ Anschlußquerschnitt  
– feindrätig mit Aderendhülse  
0,22 bis 1,5 mm<sup>2</sup>  
– eindrätig 0,22 bis 2,5 mm<sup>2</sup>

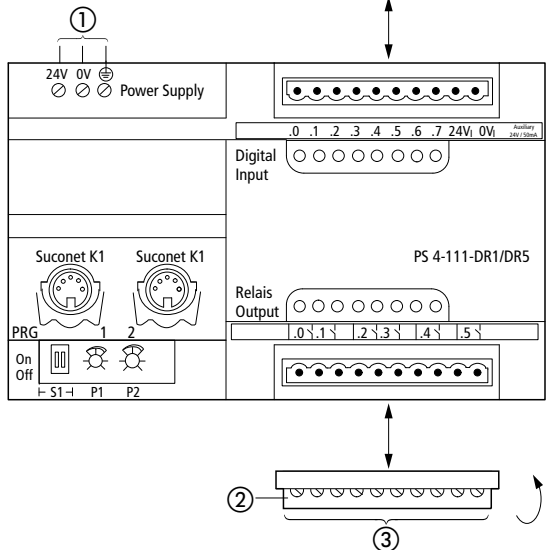

01/98 AWA 27-1260

GB

- ① Screw terminal  
Connection cross sections
  - flexible with ferrule  
0,22 to 2.5 mm<sup>2</sup> (AWG 13)
  - without ferrule  
0,22 to 2.5 mm<sup>2</sup> (AWG 13)
- ② Plug-in screw terminal
- ③ Terminal cross-sections
  - flexible with ferrule  
0,22 to 1.5 mm<sup>2</sup> (AWG 16)
  - without ferrule  
0,22 to 2.5 mm<sup>2</sup> (AWG 13)

F

- ① Bornier à vis  
Section de raccordement
  - avec embout  
0,22 à 2,5 mm<sup>2</sup>
  - sans embout  
0,22 à 2,5 mm<sup>2</sup>
- ② Bornier à vis enfichable
- ③ Section de raccordement
  - avec embout  
0,22 à 1,5 mm<sup>2</sup>
  - sans embout  
0,22 à 2,5 mm<sup>2</sup>

I

- ① Morsetti a vite  
Sezione del cavo
  - flessibile, con guaina  
0,22 a 2,5 mm<sup>2</sup>
  - rigido 0,22 a 2,5 mm<sup>2</sup>
- ② Morsetto a vite sfilabile
- ③ Sezione del cavo
  - flessibile, con guaina  
0,22 a 1,5 mm<sup>2</sup>
  - rigido 0,22 a 2,5 mm<sup>2</sup>

E

- ① Terminales roscados  
Secciones de conexión
  - flexible con casquillo  
0,22 a 2,5 mm<sup>2</sup>
  - macizo 0,22 a 2,5 mm<sup>2</sup>
- ② Terminal roscado
- ③ Secciones de conexión
  - flexible con casquillo  
0,22 a 1,5 mm<sup>2</sup>
  - macizo 0,22 a 2,5 mm<sup>2</sup>

D

GB

F

I

E



Adreßcodierung nur bei ausgeschalteter Stromversorgung erlaubt!

Always switch off the power supply when setting the address coding!

Coupez toujours l'alimentation courant avant de procéder au codage des adresses !

La codifica degli indirizzi è possibile solo se l'alimentazione è spenta!

¡Codificar las direcciones sólo con la alimentación desconectada!

Schalterstellung im Auslieferungszustand

Factory setting

Position à la livraison

Impostazione di fabbrica

Posición de entrega

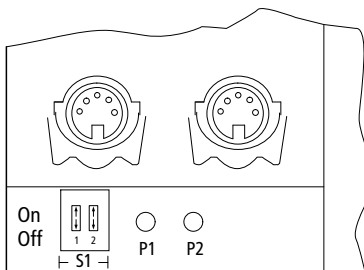

<b>S1</b>	1	2
1	1	1

0 = off/open/ouvert/aperto/abierto  
1 = on/close/fermé/chiuso/cerrado

### S1

Busabschlußwiderstände

Bus terminating resistors

Résistances de terminaison de bus

Resistenze di terminazione bus

Resistencias terminales del bus

### S1

1. Gerät 1 <sup>st</sup> device 1 <sup>er</sup> appareil 1° apparecchio 1° aparato	2. 2 <sup>nd</sup> 2 <sup>ème</sup> 2° 2°	...	letztes Gerät last device dernier appareil ultimo apparecchio último aparato
1	1	0	0
2	1	0	0

0 = off/open/ouvert/aperto/abierto  
1 = on/close/fermé/chiuso/cerrado

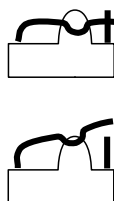
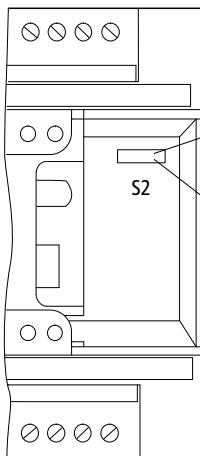

Master-Modus (Auslieferungszustand)

Master mode (Factory setting)

Mode maître (Position à la livraison)

Modo di master (Impostazione di fabbrica)

Modo de maestro (Posición de entrega)

Slave-Modus

Slave mode

Mode esclave

Modo di slave

Modo de slave

Montage  
 Fitting  
 Montage  
 Montaggio  
 Montaje

Montage auf 35-mm-Hutschiene ① (waagrecht und senkrecht)  
 Fitting on 35 mm top-hat rail ① (horizontal and vertical)  
 Montage sur profilé-support 35 mm ① (horizontal ou vertical)  
 Montaggio su guida DIN 35 mm ① (orizzontale o verticale)  
 Montaje sobre guía simétrica de 35 mm ① (horizontal y vertical)

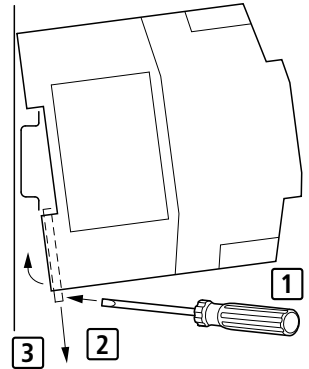
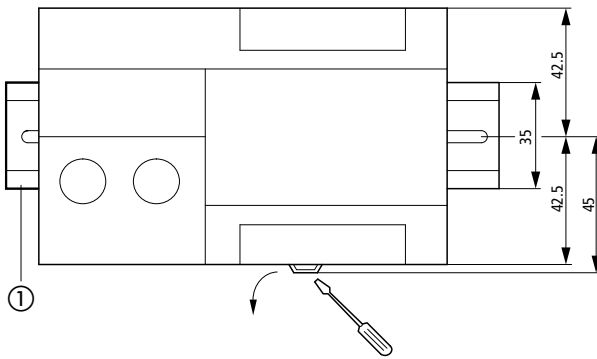

01/98 AWA 27-1260

Montage auf Montageplatte (waagrecht und senkrecht)  
 Fitting on mounting plate (horizontal and vertical)  
 Montage horizontal ou vertical sur plaque de montage  
 Montaggio su piastra di montaggio (orizzontale o verticale)  
 Montaje sobre placa (horizontal y vertical)

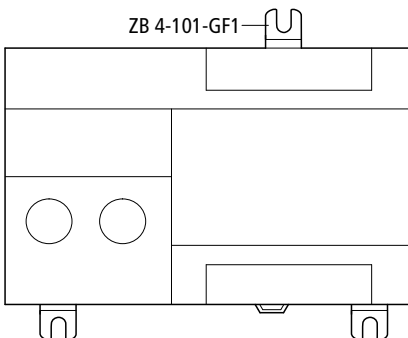

Bohrschablone M 1:1

Template for holes, scale 1:1

Gabarit de perçage, échelle 1:1

Dima di foratura, scala 1:1

Plantilla para taladros, escala 1:1

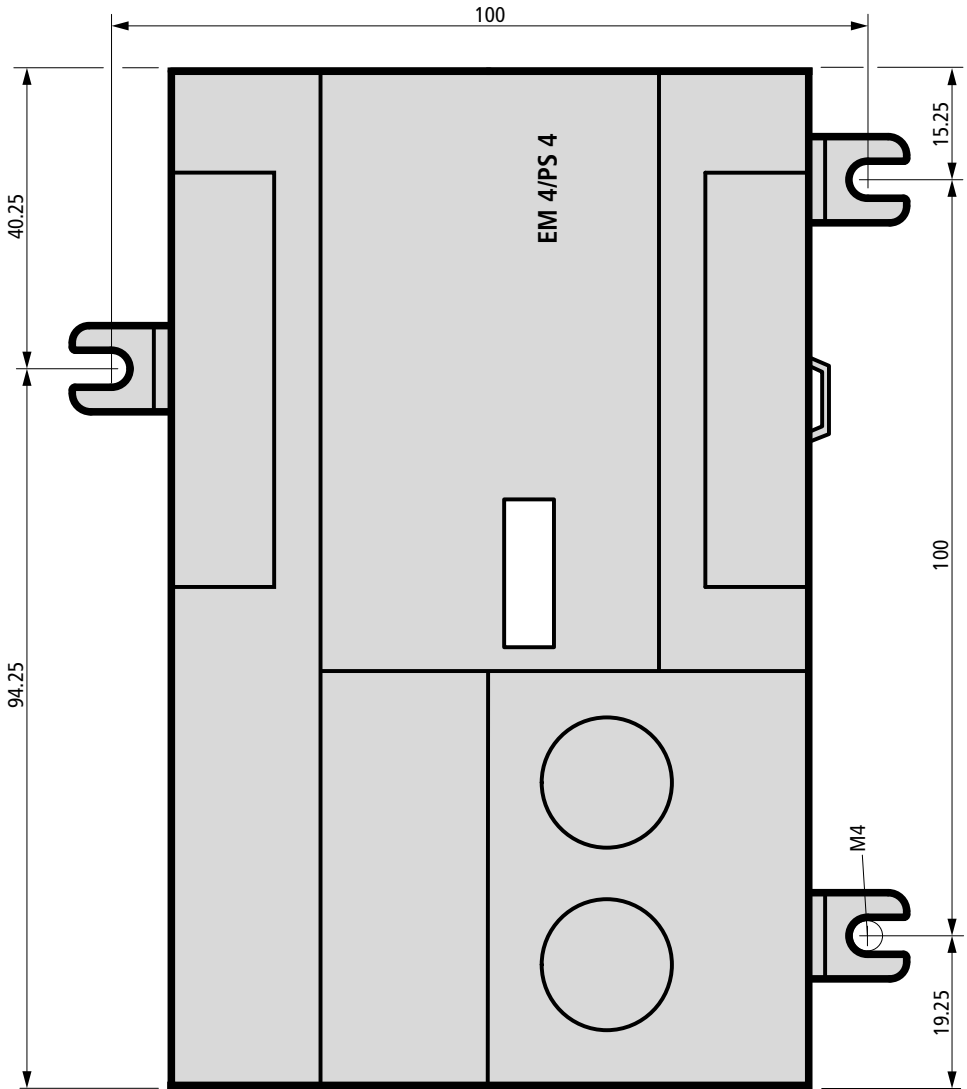

01/98 AWA 27-1260