

## Device Description

**PC based HMI-PLC  
XVC/XCC-601**

12/05 AWB2720-1522GB

All brand and product names are trademarks or registered trademarks of the owner concerned.

1<sup>st</sup> published 2004, edition date 12/05

© Moeller GmbH, 53105 Bonn

Authors: Gerhard Fischbacher, Christian Bucker  
Production: Thomas Kracht

All rights reserved, including those of the translation.

No part of this manual may be reproduced in any form (printed, photocopy, microfilm or any other process) or processed, duplicated or distributed by means of electronic systems without written permission of Moeller GmbH, Bonn.

Subject to alteration without notice.

Moeller GmbH does not accept any liability for damages arising from the use of any incorrect or incomplete information contained in this documentation or any information missing therefrom.



## Warning! Dangerous electrical voltage!

---

### Before commencing the installation

- Disconnect the power supply of the device.
- Ensure that devices cannot be accidentally restarted.
- Verify isolation from the supply.
- Earth and short circuit.
- Cover or enclose neighbouring units that are live.
- Follow the engineering instructions (AWA) of the device concerned.
- Only suitably qualified personnel in accordance with EN 50110-1/-2 (VDE 0105 Part 100) may work on this device/system.
- Before installation and before touching the device ensure that you are free of electrostatic charge.
- The functional earth (FE) must be connected to the protective earth (PE) or to the potential equalisation. The system installer is responsible for implementing this connection.
- Connecting cables and signal lines should be installed so that inductive or capacitive interference does not impair the automation functions.
- Install automation devices and related operating elements in such a way that they are well protected against unintentional operation.
- Suitable safety hardware and software measures should be implemented for the I/O interface so that a line or wire breakage on the signal side does not result in undefined states in the automation devices.
- Ensure a reliable electrical isolation of the low voltage for the 24 volt supply. Only use power supply units complying with IEC 60364-4-41 (VDE 0100 Part 410) or HD 384.4.41 S2.
- Deviations of the mains voltage from the rated value must not exceed the tolerance limits given in the specifications, otherwise this may cause malfunction and dangerous operation.
- Emergency stop devices complying with IEC/EN 60204-1 must be effective in all operating modes of the automation devices. Unlatching the emergency-stop devices must not cause restart.
- Devices that are designed for mounting in housings or control cabinets must only be operated and controlled after they have been installed with the housing closed. Desktop or portable units must only be operated and controlled in enclosed housings.
- Measures should be taken to ensure the proper restart of programs interrupted after a voltage dip or failure. This should not cause dangerous operating states even for a short time. If necessary, emergency-stop devices should be implemented.
- Wherever faults in the automation system may cause damage to persons or property, external measures must be implemented to ensure a safe operating state in the event of a fault or malfunction (for example, by means of separate limit switches, mechanical interlocks etc.).



## Proper use

The device must only be used for the applications specified in the device description and only in conjunction with the components recommended by Moeller GmbH.

## Warning

Trouble-free and safe operation of the product can only be ensured if the measures relating to proper transport, storage, assembly, installation and careful operation are strictly observed.

The device must not be switched on when it is covered with condensation. When changing its location from cold to warm allow the device to acclimatize to the new conditions before commissioning.

No warranty claims will be recognized for faults arising from the improper handling of the device.

The device should not be used for the implementation of any safety functions relating to the protection of personnel and machinery.

No liability is accepted for claims for damages arising from a failure or functional defect in the device.

All data specified in this document does not represent guaranteed specifications in the legal sense.

## **Safety instructions for the user**

This device description contains the information required for the proper use of the products described therein. Sections 1 to 12 address technically qualified personnel and Section 13 onwards addresses personnel not requiring any technical knowledge.

Qualified personnel in the sense of the safety instructions given in this device description or on the product itself are persons who:

as engineering personnel are either familiar with the safety concepts of automation,

or as operating personnel, are instructed in the use of automation components and are familiar with the contents of this device description relating to the operation of the device,

or as commissioning or service personnel are suitably trained for the repair of automation devices and are authorized to commission circuits and devices/systems in accordance with standard safety engineering principles.

## Contents

<b>1</b>	<b>Explanation of symbols</b> .....	<b>5</b>
<b>2</b>	<b>Introduction</b> .....	<b>7</b>
<b>3</b>	<b>Device versions</b> .....	<b>9</b>
3.1	Specifications.....	10
3.2	Accessories.....	11
3.3	Designing.....	11
<b>4</b>	<b>Features</b> .....	<b>13</b>
<b>5</b>	<b>Commissioning</b> .....	<b>15</b>
5.1	Overview of connections.....	15
5.2	Inserting the CompactFlash™ .....	16
5.3	Inserting the battery .....	17
5.4	Connecting the power supply.....	18
5.5	Preparing the shield connections.....	19
5.6	Connecting the programming interface.....	20
5.7	CAN interface.....	21
5.8	Connection for keyboard.....	24
5.9	Connection for ProfibusDP (Optional).....	24
5.10	Connection for COM1 serial interface (RS232).....	25
5.11	Connection for COM2 serial interface (RS232).....	25
5.12	Connecting a DVI-Panel to a XCC-601 .....	26
<b>6</b>	<b>Operation</b> .....	<b>27</b>
6.1	Startup behaviour.....	27
6.2	Shutdown behaviour .....	27
6.3	PLC operating states .....	28
6.4	Changing operating mode.....	29
6.5	Startup behaviour/startup.....	30
6.6	Program transfer .....	30
6.7	System settings.....	31
6.8	Behavior of the PLC on Errors .....	32
<b>7</b>	<b>Mounting instructions</b> .....	<b>33</b>
7.1	General mounting instructions .....	33
7.2	Mounting in the front panel - General .....	33
7.3	Mounting in the front panel – ATEX.....	34
7.4	Front panel cutout XVC-601 10,4” .....	35
7.5	Front panel cutout XVC-601 12,1“ .....	36
7.6	Front panel cutout XVC-601 15“ .....	37
7.7	Mechanical dimensions XVC-601 10,4”.....	38
7.8	Mechanical dimensions XVC-601 12,1“.....	39
7.9	Mechanical dimensions XVC-601 15”.....	40
7.10	Mechanical dimensions XCC-601 .....	41
<b>8</b>	<b>Notes on the touch-screen</b> .....	<b>43</b>
8.1	Basic touch-screen function.....	43
8.2	Power up function test .....	44
8.3	Cleaning and maintenance of the touch-screen .....	45

<b>9</b>	<b>Display, backlight, contrast .....</b>	<b>47</b>
9.1	Contrast .....	47
9.2	Backlight .....	47
<b>10</b>	<b>Diagnostics.....</b>	<b>47</b>
<b>11</b>	<b>Maintenance and repair.....</b>	<b>49</b>
<b>12</b>	<b>Technical data .....</b>	<b>51</b>
<b>13</b>	<b>Disposal .....</b>	<b>55</b>
<b>14</b>	<b>EU Conformity and Standards .....</b>	<b>56</b>
<b>15</b>	<b>Revision history .....</b>	<b>57</b>
<b>16</b>	<b>Alphabetical index .....</b>	<b>59</b>

## 1 EXPLANATION OF SYMBOLS

### Danger warnings

The following information is for your personal safety and the prevention of damage to the device described or connected devices.

Safety instructions and warnings for the prevention of danger to the life and health of users or service personnel, and for the prevention of damage are highlighted in this document by the following pictograms. "Warning" and "Information" pictograms are shown in this document.

### Warnings indicate the following:

Death, serious injury or substantial material damage may occur if the related safety measures are not implemented.

The individual "Warning" pictograms have the following meaning:



#### Caution! General!

An instruction to be observed in order to ensure protection against hazards and the safe operation of the device. The specified procedure should be observed.



#### Caution! Electric shock!

Persons may be exposed to dangerous voltages that occur in electrical systems. There is a danger of electric shock if a live part is touched.



#### Caution! Observe ESD measures!

Electrostatic discharge may destroy electronic components.

### Information pictograms indicate the following:

Important information about the product or the relevant section of the document, requiring the particular attention of the reader.

The "Information" pictogram has the following meaning:

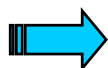

Indicates important and instructional information.



## 2 INTRODUCTION

### Features of the XVC/XCC-601 devices

- PC-COMPATIBLE COMPUTER CORE
- STANDARD FIELDBUS INTERFACES  
CANopen, PROFIBUS-DP (Option)
- ETHERNET ONBOARD
- EXCHANGEABLE COMPACTFLASH™
- PROGRAMMABLE TO IEC61131 (IL, LD, FBD, SFC, ST, CFC)
- INFRARED or RESISTIVE TOUCH-TECHNOLOGY
- IP65 FRONT
- COMPACT (XVC) or REMOTE DVI-PANEL (XCC)

The XVC-601 series graphic display PLC combines in one device a graphical operator panel with touch-screen and a powerful compact PLC. The XCC-601 series can be used together with a remote DVI-touch panel or stand alone without display (headless). This future-oriented device concept offers a wide range of automation and networking options.

The PLC is programmed in compliance with the IEC61131 industrial standard. The graphical screen masks are designed effectively and simply using the visualization tool EPAM and EXCEL. This makes the display PLC a universal device for automation applications.

The integration of third-party systems (I/Os, drives etc.) via standard fieldbus interfaces (CANopen) and their integration in the overall system offers access to a wide range of process optimized peripheral components.

Thanks to the integrated Ethernet interface the XVC/XCC-601 series graphic display PLCs have the capabilities for Web applications.

### Application range

The XVC/XCC-601 series graphic display PLC is designed for controlling, operating and monitoring machines and plants. The integrated touch technology (infra-red or resistive) ensures fast and simple operation. The rugged and compact design allows the implementation of applications that were previously impossible due to the space and cost requirements involved.

The high degree of protection (XVC front IP65) and the omission of any moving parts (hard disks, fans) makes the devices ideal for robust use in rugged industrial environments directly at the machine.

The devices can be installed in control panels or control desks (XVC) without any problem. The devices are not designed for mobile use.

This device description is a reference for the technical data, installation, terminals, commissioning, operation, and maintenance of all XVC/XCC-601 versions. The illustrations in this document are for the 10.4" device version (→ Section 3), unless otherwise stated. The designation and function of the connections and signals are the same for all versions.



### 3 DEVICE VERSIONS

The term XVC-601 stands for the following versions.

XVC-601 Device types				
Type designation	Display	Fieldbus	Resolution	Power-supply
<b>XVC-601-GTx-10-V1-000</b>	10.4" TFT color	CAN	VGA 640x480	24 VDC
<b>XVC-601-GTx-10-DPM-V1-000</b>	10.4" TFT color	CAN, ProfibusDP	VGA 640x480	24 VDC
<b>XVC-601-GTx-12-V1-000</b>	12.1" TFT color	CAN	SVGA 800x600	24 VDC
<b>XVC-601-GTx-12-DPM-V1-000</b>	12.1" TFT color	CAN, ProfibusDP	SVGA 800x600	24 VDC
<b>XVC-601-GTx-15-V1-000</b>	15" TFT color	CAN	XGA 1024x768	24 VDC
<b>XVC-601-GTx-15-DPM-V1-000</b>	15" TFT color	CAN, ProfibusDP	XGA 1024x768	24 VDC

The following front plate versions are available:

Touch type x		Standard aluminium front with Moeller membrane seal
	I	Scratch resistant infrared touch-screen with laminated glass
	R	seamless resistive touch-screen

The term XCC-601 stands for the following versions.

XCC-601 Device types				
Type designation	Display	Fieldbus	Resolution	Power-supply
<b>XCC-601-DVI-V1-000</b>	see DVI-Panel	CAN	see DVI-Panel	24 VDC
<b>XCC-601-DVI-DPM-V1-000</b>	see DVI-Panel	CAN, ProfibusDP	see DVI-Panel	24 VDC

**3.1 SPECIFICATIONS**

Specifications XVC-601:

<b>XVC-601-GTI-10-V1-000</b>	Order No.: 272547  Graphic-Display-PLC 10.4" TFT color, Pentium 200MHz, 64MB DRAM, 32kB NVSRAM, CF-Interface, IR-touch-screen Interface: CAN, 1 x RS232, Ethernet 10/100MB with CompactFlash™ and Runtime-System
<b>XVC-601-GTR-10-V1-000</b>	Order No: 281683 same as Order No: 272547 but with <b>resistive touch-screen</b>
<b>XVC-601-GTI-10-DPM-V1-000</b>	Order No.: 272550 same as Order No.: 272547 but with additional <b>ProfibusDP Master. As from HW-Index 0003 Profibus-DP Master/MPI or Slave</b>
<b>XVC-601-GTR-10-DPM-V1-000</b>	Order No: 281686 same as Order No: 272550 but with <b>resistive touch-screen</b>
<b>XVC-601-GTI-10-DPS-V1-000</b>	Order No.: 272554 same as Order No.: 272547 but with additional <b>ProfibusDP Slave. As from HW-Index 0003 replaced by Order No. 272550</b>
<b>XVC-601-GTR-10-DPS-V1-000</b>	Order No: 281689 same as Order No: 272554 but with <b>resistive touch-screen As from HW-Index 0003 replaced by Order No. 281686</b>
<b>XVC-601-GTI-12-V1-000</b>	Order No.: 272548 same as Order No.: 272547 but with <b>12,1" TFT color</b>
<b>XVC-601-GTR-12-V1-000</b>	Order No: 281684 same as Order No: 272548 but with <b>resistive touch-screen</b>
<b>XVC-601-GTI-12-DPM-V1-000</b>	Order No.: 272552 same as Order No.: 272548 but with additional <b>ProfibusDP Master. As from HW-Index 0003 Profibus-DP Master/MPI or Slave</b>
<b>XVC-601-GTR-12-DPM-V1-000</b>	Order No: 281687 same as Order No: 272552 but with <b>resistive touch-screen</b>
<b>XVC-601-GTI-12-DPS-V1-000</b>	Order No.: 272555 same as Order No.: 272548 but with additional <b>ProfibusDP Slave. As from HW-Index 0003 replaced by Order No. 272552</b>
<b>XVC-601-GTR-12-DPS-V1-000</b>	Order No: 281700 same as Order No: 272555 but with <b>resistive touch-screen As from HW-Index 0003 replaced by Order No. 281687</b>
<b>XVC-601-GTI-15-V1-000</b>	Order No.: 272549 same as Order No.: 272547 but with <b>15" TFT color</b>
<b>XVC-601-GTR-15-V1-000</b>	Order No: 281685 same as Order No: 272549 but with <b>resistive touch-screen</b>
<b>XVC-601-GTI-15-DPM-V1-000</b>	Order No.: 272553 same as Order No.: 272549 but with additional <b>ProfibusDP Master. As from HW-Index 0003 Profibus-DP Master/MPI or Slave</b>
<b>XVC-601-GTR-15-DPM-V1-000</b>	Order No: 281688 same as Order No: 272553 but with <b>resistive touch-screen</b>
<b>XVC-601-GTI-15-DPS-V1-000</b>	Order No.: 272556 same as Order No.: 272549 but with additional <b>ProfibusDP Slave. As from HW-Index 0003 replaced by Order No. 272553</b>
<b>XVC-601-GTR-15-DPS-V1-000</b>	Order No: 281701 same as Order No: 272556 but with <b>resistive touch-screen As from HW-Index 0003 replaced by Order No. 281688</b>

Specifications XCC-601:

<b>XCC-601-DVI-V1-000</b>	Order No: 274071  Grafik-Display PLC with DVI-Interface Pentium 200MHz, 64MB DRAM, 32kB NVSRAM, CF-Interface, DVI- Interface Interface: CAN, 1 x RS232, Ethernet 10/100MB, 1 x DVI, 1 x Touch/PowerSupply with CompactFlash™ and Runtime-System
<b>XCC-601-DVI-DPM-V1-000</b>	Order No: 274072 same as Order No: 274071 but with additional <b>ProfibusDP Master. As from HW-Index 0003 Profibus-DP Master/MPI or Slave</b>
<b>XCC-601-DVI-DPS-V1-000</b>	Order No: 274073 same as Order No: 274071 but with additional <b>ProfibusDP Slave As from HW-Index 0003 replaced by Order No. 274072</b>

**3.2 ACCESSORIES**

<b>Programming cable</b>	<p><b>XT-SUB-D-SUB-D</b> Order No.: <b>264114</b></p> <p>Programming cable RS232 Null modem (serial connection)</p> <p><b>XT-CAT5-KG2,0</b> Order No.: <b>262184</b></p> <p>RJ45 programming cable Ethernet 1:1 (Ethernet connection via hub)</p> <p><b>XT-CAT5-X-2</b> Order No.: <b>256487</b></p> <p>RJ45 programming cable Ethernet crosslink (direct Ethernet connection)</p>
<b>Batterie</b>	<p><b>XT-CPU-BAT2</b> Order No.: <b>264115</b></p>
<b>DVI-Panel for XCC-601</b>	<p><b>XV-DVI-GTR-06-000</b> Order No. <b>272557</b> DVI-Touchpanel 6,4", resistive touch-screen, resolution VGA 640x480</p> <p><b>XV-DVI-GTR-10-000</b> Order No. <b>274065</b> DVI-Touchpanel 10,4", resistive touch-screen, resolution VGA 640x480</p> <p><b>XV-DVI-GTR-12-000</b> Order No. <b>274066</b> DVI-Touchpanel 12,1", resistive touch-screen, resolution SVGA 800x600</p> <p><b>XV-DVI-GTR-15-000</b> Order No. <b>274067</b> DVI-Touchpanel 15", resistive touch-screen, resolution XGA 1024x768</p> <p><b>XV-DVI-GTI-10-000</b> Order No. <b>274068</b> DVI-Touchpanel 10,4", Infrared touch-screen, resolution VGA 640x480</p> <p><b>XV-DVI-GTI-12-000</b> Order No. <b>274069</b> DVI-Touchpanel 12", Infrared touch-screen, resolution SVGA 800x600</p> <p><b>XV-DVI-GTI-15-000</b> Order No. <b>274070</b> DVI-Touchpanel 15", Infrared touch-screen, resolution XGA 1024x768</p>

**3.3 DESIGNING**

<b>Moeller XSoft</b> (on CD)	<p>XSoft CD Order No.: <b>255930</b></p> <p>Consisting of:</p> <ul style="list-style-type: none"> <li>- XSoft -&gt; IEC61131 software</li> <li>- Documentation in PDF format</li> </ul>
<b>Moeller XSoft-EPAM</b>	<p>XSoft-EPAM CD Order No.: <b>281648</b></p> <p>Consisting of:</p> <ul style="list-style-type: none"> <li>- XSoft-EPAM -&gt; Visualization-Software</li> <li>- Documentation in PDF format</li> </ul>



**4 FEATURES**

Feature		Comment	
<b>Display (XVC)</b>	Graphic	Size	10,4" / 12,1" / 15"
	Type	TFT	256k colors
	Resolution	Pixels	640 x 680 / 800 x 600 / 1024 x 768
<b>Touch</b>	Infrared touch-screen	Resolution	81 x 61 / 92 x 70 / 115 x 87
	Resistive touch-screen	Resolution	12 Bit (0-4096)
<b>PLC</b>	Languages	IEC61131	IL, LD, FBD, SFC, ST, CFC
	Debug options	Yes	Online change, breakpoint, trace, flow control
	PLC program	KByte	1024
	PLC data	KByte	256
	Retain data	KByte	32 kB
	Multi-tasking	Yes	
	Network variables	Yes	Ethernet or CAN
	Cycle time/k instructions	ms	Normally 0.07 ms
	Real-time clock	Yes	Battery-backed
	<b>Visualization</b>	Memory for visualization	MByte
Messages		Number	Max. 32767
Alarms		Number	Max. 1008
Alarm history		Number	Max. 512
Process variables		Number	Normally 3000
Process screen pages		Number	Max. 21000
Online languages		Number	Normally 10
Character languages		Yes	e.g. Chinese, Japanese,...
Recipes		Yes	Can be edited in ASCII text format
Password		Yes	Normally 10 levels
<b>Communication</b>	COM1 (RS232)	kBit/s	Max. 115,2KB
	CAN (CANopen)	kBit/s	CAN master, max. 500 Default: 125
	Ethernet	MBit/s	10/100
	ProfibusDP	MBit/s	Max. 12 (Option see device versions)
	Remote maintenance	Yes	With external modem serial or via Ethernet (e.g. with ISDN router)
<b>Exchangeable memory</b>	CompactFlash™	MByte	>= 32 MB
	Software update via CompactFlash™	Yes	PLC project, visualization, runtime system

The number of designable process screen pages, messages, languages etc. is restricted by the memory available for visualization. The memory required per image greatly depends on the application concerned, and is mainly determined by the size and number of images (PCX) used. 100 KBytes and more may be required for showing an image with a resolution of 640\*480 pixels. If an image of this size is designed on each screen page, the number of possible screen pages would be less than 220 (with 32MB CompactFlash).

These specifications are based on typical sizes that are used in real projects. With sufficient memory, these values can be exceeded. However, this will result in longer reaction times and screen change times. (see also EPAM manual)

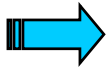

**In the system the PLC program has priority over the visualization. Therefore the PLC program should not take up all the CPU time otherwise operation and visualization will be impossible or very slow. Delays in the visualization may occur during file transfers (such as project downloads, FTP, WEB servers), or during communication with the development system (e.g. PLC debugging) as the visualization has the lower priority.**

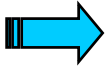

**CompactFlash™ memory media are NOT suitable for cyclical data logging due to the limited number of write cycles (normally 1 000,000).**

## 5 COMMISSIONING

### 5.1 OVERVIEW OF CONNECTIONS

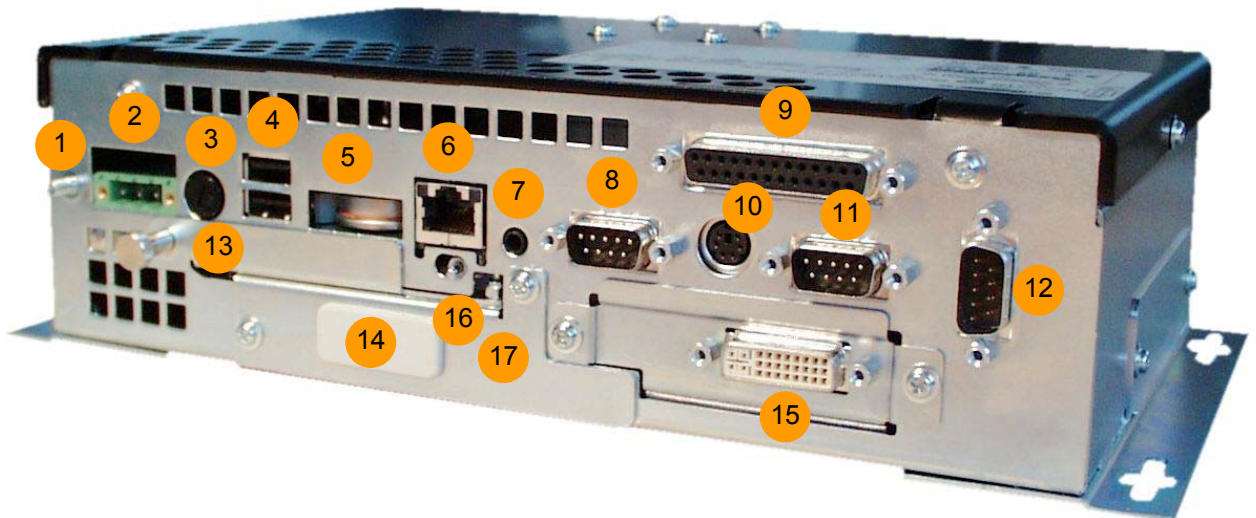

No.	Element	Description
1	Function earth	→ Section 5.4
2	24VDC power supply	→ Section 5.4
3	Fuse	→ Section 5.4
4	USB 1+2	Not supported
5	Battery	→ Section 5.3
6	RJ45 Ethernet	→ Section 5.6
7	Audio Line Out	Not supported
8	CAN connector 9-pole Sub-D, male	→ Section 5.7
9	LPT connector	Not supported
10	PS2 keyboard	→ Section 5.8
11	RS232 COM1	→ Section 5.10
12	COM2 for Touch of DVI-Panel (only XCC)	→ Section 5.11
13	CompactFlash™ Interface	→ Section 5.2
14	ProfibusDP (Option)	→ Section 5.9
15	Remote Video (only XCC)	→ Section 5.12
16	Betriebsartenschalter (BAS) Run/SF LED	→ Section 6.1
17	Profibus-LED (Option)	→ Section 5.9, 10

## 5.2 INSERTING THE COMPACTFLASH™

The XVC/XCC-601 series devices use a CompactFlash™ card for storing the runtime system, the application or data (e.g. recipes). A CompactFlash™ card with the pre-installed XVC/XCC-601 runtime system is already inserted when delivered.

To change the CompactFlash™, undo the cover of the CompactFlash™ interface and insert the appropriate XVC/XCC-601 runtime system. The cover must be refitted and fastened.

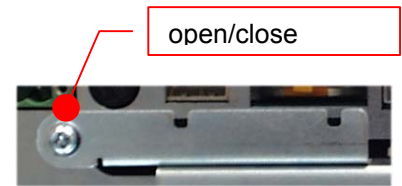

**The CompactFlash™ must only be fitted or removed with the device power supply switched off.**

**Otherwise data can be lost.**

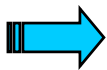

**The device cannot run without a CompactFlash™ card. Correct functioning of the device can only be ensured by using CompactFlash™ cards obtained from the original accessories.**

### 5.3 INSERTING THE BATTERY

The internal battery is used for backing up the real-time clock. The battery is already inserted when delivered. It can be replaced during operation

1. pull out the battery with the shackle
2. Replace battery

Shackle with  
date



The retain PLC data will be written to a non volatile flash memory automatically at power down.

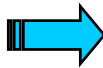

**When replacing the battery during power off, date and time must be set after power on.**



**When replacing the battery please observe ESD measures!**



**Caution!**

**Risk of explosion if battery is replaced by an incorrect type. Replacement of battery must be done by instructed service personal only.**

**Used batteries should be disposed via specialized dealers.**

**5.4 CONNECTING THE POWER SUPPLY**

The XVC/XCC-601 device belongs to protection class 3. The system power supply must be provided with a 24VDC **SELV** voltage (→ Section 12). The power supply is NOT isolated. The GND connection is directly connected to the housing potential. The device is protected with a fuse (note disconnection capacity → Section 12). A reverse polarity protective device is used to protect the device in the event of reversed poles. Operation, however, is only possible if the connection was made correctly. Connections for the XVC/XCC-601 must comply with specific, local regulations.

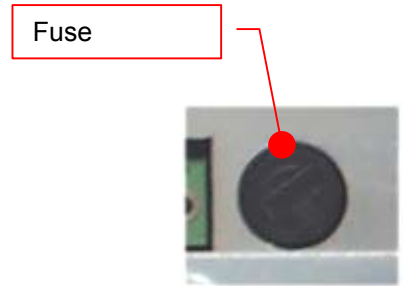

The connection must be made as follows:

1. The cross-section of the power supply cable must be at least 0.75 mm<sup>2</sup> and a maximum of 2.5 mm<sup>2</sup>.
2. A flexible lead or wire can be used for the connection.
3. The current consumption (→ Section 12) must be taken into account when implementing the power supply.
4. The functional earth is not compulsory for operation. But it can help to avoid disturbance caused by potential differences.
5. The GND connection is directly connected to the housing potential
6. For safety reasons the wires should be fixed together near by the connector

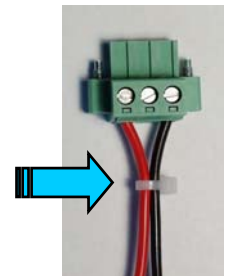

The plug connector (socket connector with screw terminals) is supplied with the device for connection. (WAGO 1777992)

**Connector assignment**

Designation	Function
+24 VDC	+24VDC power supply
	reserved
0 V	0V power supply

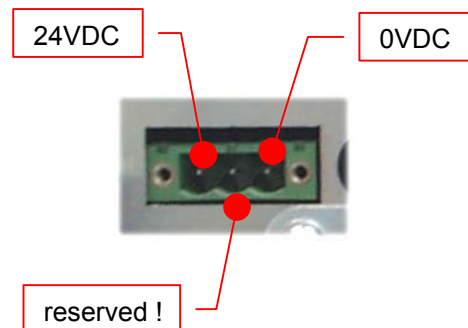

(plug connector: 3pol Phoenix MSTB2.5/3-GF-5.08, RM 5.08mm, Phönix Ord.Nr 1776511)



**In the event of reverse connection and simultaneous connection of a further 0V connection, e.g. GND connection of the COM1 interface, the fault current flows via this 0V connection. If the housing is not lying well set on the 0V potential, the result can be destruction of the device or of the external components!**



**Only the specified fuse must be used. An over-dimensioned fuse can result in the destruction of the device or of the external components!**

## 5.5 PREPARING THE SHIELD CONNECTIONS

The preparation of the data and signal cables is an important factor for the electromagnetic compatibility (EMC) of the XVC/XCC-601, both in terms of interference immunity and emission.

The **RS232**, **LPT** and **CAN** interface are connected via D-Subminiature plug connectors in accordance with DIN 41652. Only use metal or metallised connector casings with a cable clamp for strain relief fastened or clamped on the connector. The clamping of the cable shield ensures an optimum contact area and a low impedance connection with the connector casing of the XVC/XCC-601 display PLC.

The following procedure is recommended for making the low-impedance connection for the cable shield:

1. Strip the cable.
2. Shorten the exposed shield braid by approx. 3 cm.
3. Turn back the braid over the cable sheath.
4. Use a heat shrinkable tubing or rubber grommet to cover the exposed cable sheath with the folded back shield braid so that 5 to 8 mm of exposed cable shield is left at the sheath end and is cleanly covered at the back.
5. Fit the connector
6. The cable is then fastened at the exposed shield braid and the cable sheath below it directly underneath the cable clamp strap of the

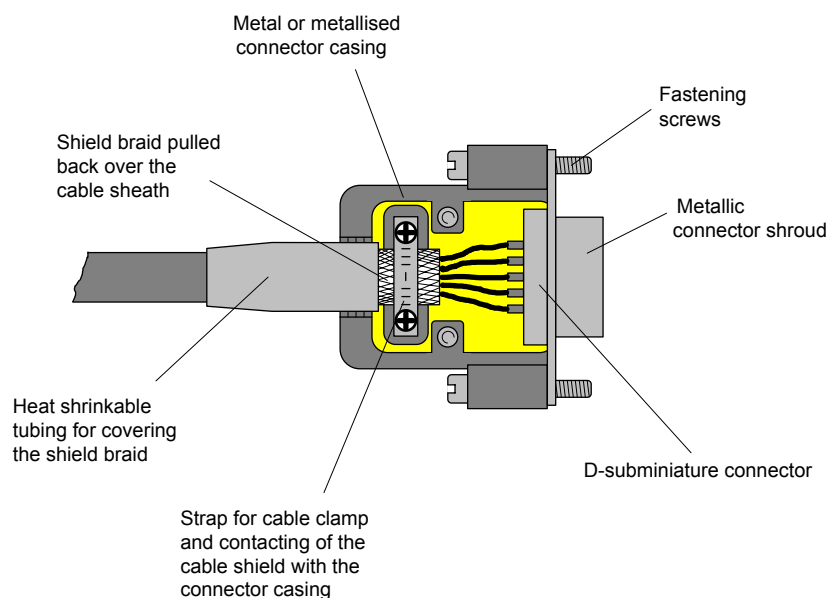

connector casing.

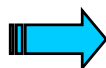

**Connection work should be carried out with special care in order to ensure trouble-free operation. The EMC values stated in the technical data can only be guaranteed if the cables are prepared according to the following specifications.**

**5.6 CONNECTING THE PROGRAMMING INTERFACE**

The programming is carried out via the standard Ethernet interface (RJ45). The connection to the programming PC is implemented using a standard Ethernet cable (1:1) via a hub or directly using a crosslink cable. The cables are also available as an accessory (➔ Section 3.2). Before the device is connected to the Ethernet network, the IP address of the device and the programming PC must be set (➔ Section 6.7).

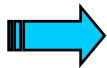
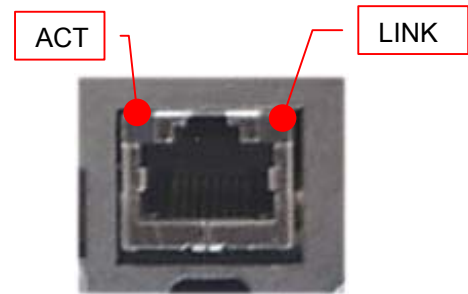

**IP addresses can be obtained from your system or network administrator. IP addresses must be uniquely defined in an Ethernet network. The IP address of all networks and of the programming PC must be in the same subnetwork (e.g. 192.168.0.xxx).**

Two diagnosis LEDs are available:

- Orange: LINK (connection to HUB or to another device)
- Green: ACT (sending or receiving)

Cables connected to the programming interface (Ethernet or serial) must be laid separately from the low-voltage cables.



**To ensure disturbance-free operation, it is strongly recommended to use STP-cables.**

**Connector assignment**

**RJ45 connector**

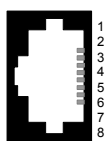

Socket, 8pole  
RJ45

Pin No.	Signal	Description
1	TXD	
2	TXD+	
3	RXD+	
4	-	
5	-	
6	RXD	
7	-	
8	-	

Alternatively, programming can also be implemented via the RS232 serial interface on COM1. This interface is not isolated. The GND connection is implemented directly on the housing potential (➔ Section 12).

Cables connected to the programming interface (Ethernet or serial) must be laid separately from the low-voltage cables.

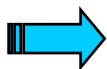

**A detailed description of the project download is provided in the “XSoft” system description or in the appropriate software documentation.**

**5.7 CAN INTERFACE**

The communication interface is defined in accordance with the CiA CAN Specification V2.0 part B. The fully-integrated CAN unit supports the sending and receiving of frames with an 11-bit identifier. The type of configuration selected depends on the software protocol. The baud rate can be selected in a wide range, and only the standard CiA baud rates are implemented. The XVC/XCC-601 is the master on the CAN bus.

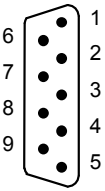
<b>CAN connector</b>			
Sub-D 9 Pole male			
<b>Connector</b>	Pin No.	Assignment	Function
	1	-	
	2	CAN LOW	Negative data signal
	3	GND	Signal Ground (ground potential)
	4	-	
	5	-	
	6	GND	Signal Ground (ground potential)
	7	CAN HIGH	Positive data signal
	8	-	
	9	-	
	Case	Case	Cable shield



**The CAN interface is isolated.**  
**The max. baud rate is 500kBit/s.**



**The terminating resistor must be implemented externally, e.g. in the connector, and is not part of the device.**  
**The CAN connector is not provided with a supply for third-party devices.**

**A detailed description of the wiring is provided in the "XSoft" system description**

**Wiring instructions**

The stations on the bus system are connected via fieldbus lines complying with ISO 11898. The cables must accordingly have the following electrical characteristics:

Parameter	Abbreviation	Unit	Value min.	Value nom.	Value max.	Note
Impedance	Z	$\Omega$	108	120	132	Measured between two signal lines
Specific resistance		m $\Omega$ /m		70		For the receiver module, the differential voltage on the bus cable depends on cable resistance between it and the sender
Cable delay		ns/m		5		The minimum delay between to points on the bus is 0. The maximum delay is determined by the bit timing and the delays of the sender and receiver circuits

The figure shows the minimum wiring with shielding between two bus stations with the Sub-D connector as an example. A bus terminating resistor (120 Ohm between Pin 2 and Pin 7 of the Sub-D connector) must be connected at the beginning and the end of each CAN bus. Do not swap around the two signal wires!

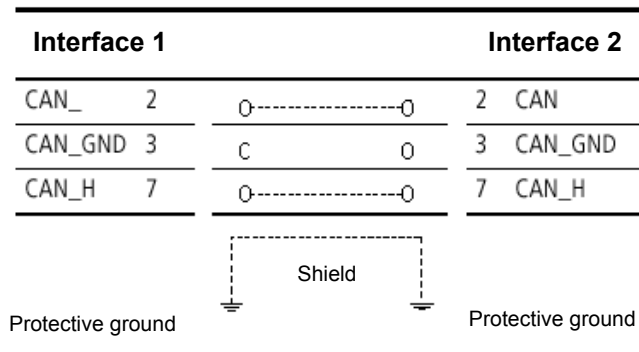

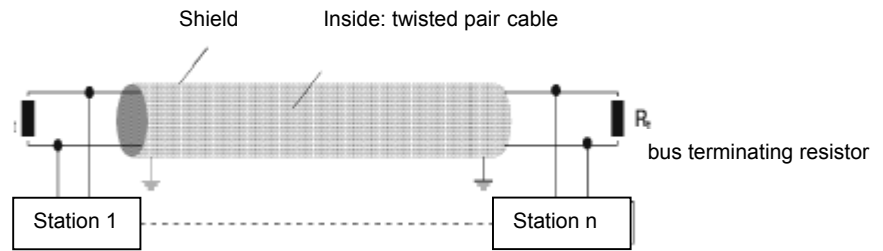

Pin 3 and 6 (CAN\_GND) are both connected internally with the CAN Ground. Pins 4, 5 and 8 must *not* be connected! The CAN bus driver is fed internally.

### Baud rate and cable lengths

Baud rate	Max. length
20kBit/sec	2500m
25kBit/sec	2000m
50kBit/sec	1000m
100kBit/sec	650m
125kBit/sec	500m
250kBit/sec	250m
500kBit/sec	100m

### 5.8 CONNECTION FOR KEYBOARD

The keyboard terminal is PC-compatible (PS2) and is only provided for testing and service tasks.

**Connector**

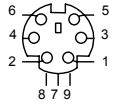

Socket 6pole  
MiniDIN

Pin No.	Signal	Description
1	KBDATA	
2	-	
3	KBGND	
4	KBVCC	Fused
5	KBGND	
6	-	

### 5.9 CONNECTION FOR PROFIBUSDP (OPTIONAL)

The ProfibusDP interface is only available in the versions, **-DPM** (ProfibusDP-Master) and **-DPS** (ProfibusDP-Slave).

**Socket**

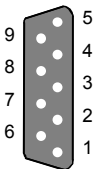

Socket 9pole  
SubD

Pin No.	Signal	Description
1	-	
2	-	
3	RXD/TXD+	
4	-	
5	GND	
6	+5V	Fused, not isolated Max. 10mA
7	-	
8	RXD/TXD-	
9	-	

Devices with Profibus-DP (-DPM) as from change index: see name plate/table and Runtime System V1.35 can be configured as DP-Master/MPI (default) or DP-Slave. The configuration can be done within the system settings (see Section 6.7 System settings, P.31)

Device	Index
XVC-601-GTR-10-DPM-V1-000	0001
XVC-601-GTR-12-DPM-V1-000	0001
XVC-601-GTR-15-DPM-V1-000	0001
XVC-601-GTI-10-DPM-V1-010	0000
XCC-601-DVI-DPM-V1-000	0002
XVC-601-GTI-10-DPM-V1-000	0003
XVC-601-GTI-12-DPM-V1-000	0002
XVC-601-GTI-15-DPM-V1-000	0003

**5.10 CONNECTION FOR COM1 SERIAL INTERFACE (RS232)**

The serial Interface COM1 is PC-compatible. This interface is not isolated. The GND connection is implemented directly on the housing potential (→ Section 12).

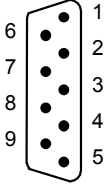
Connector	Pin No.	Signal	Description
 Connector 9pole SubD	1	DCD	
	2	RXD	
	3	TXD	
	4	DTR	
	5	GND	
	6	DSR	
	7	RTS	
	8	CTS	
	9	RI	

Cables connected to the programming interface (Ethernet or serial) must be laid separately from the low-voltage cables.



**To ensure disturbance-free operation, it is strongly recommended to use cables with shield.**

**5.11 CONNECTION FOR COM2 SERIAL INTERFACE (RS232)**

The serial Interface COM2 is available on XCC-601 devices only and is used to connect the Touch/PowerSupply cable to a DVI-Panel.

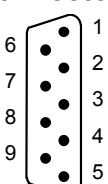
Connector	Pin No.	Signal	Description
 Connector 9pole SubD	1	-	Reserved
	2	RXD	Receive signal for touch-screen (DVI-Panel)
	3	TXD	Send signal for touch-screen (DVI-Panel)
	4	-	Reserved
	5	GND	
	6	-	Reserved
	7	-	Reserved
	8	-	Reserved
	9	12V	12VDC for 6.4" DVI-Panel

This interface is not isolated. The GND connection is implemented directly on the housing potential (→ Section 12).

Cables connected to the COM2 must be laid separately from the low-voltage cables.

The pin assignment corresponds to the PC standard with the following exception:

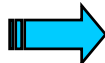

**Pin 9 is used for the 12VDC power supply of a 6.4" DVI-Panel. It is not recommended to use this power supply for larger displays, or any display with a distance over 10m. Problems due to voltage drop can occur ! The voltage is short circuit proof.**



**To ensure disturbance-free operation, it is strongly recommended to use the Touch/PowerSupply cables from the original accessories. (see DVI-Panel manual)**

**5.12 CONNECTING A DVI-PANEL TO A XCC-601**

The Remote Video Interface is only available for XCC-601 series and is used to connect a DVI-Panel. (see accessories). For details see also DVI-Panel manual.

The Video Interface is compatible to the Single Link DVI-D Standard. For practical reasons a DVI-I connector is used, where the analog output pins have no function.(not connected)

Pin-Nr	Signal	Description
1	RX2-	TMDS Data 2- Input
2	RX2+	TMDS Data 2+ Input
3	RX2/RX4 shield	TMDS Shield for Data 2 & 4
4	RX4-	Internally not connected
5	RX4+	Internally not connected
6	DDC Clock	Digital Data Channel Clock Input
7	DDC Data	Digital Data Channel Data I/O
8	Analog Vsync	Internally not connected
9	RX1-	TMDS Data 1- Input
10	RX1+	TMDS Data 1+ Input
11	RX1/RX3 shield	TMDS Shield for Data 1 & 3
12	RX3-	Internally not connected
13	RX3+	Internally not connected
14	+5 V	+5V for DDC
15	TTL Ground	
16	HPD	Hot Plug Detect
17	RX0-	TMDS Receive 0-
18	RX0+	TMDS Receive 0+
19	RX0/RX5 shield	TMDS Shield for Data 0 & 5
20	RX5-	Internally not connected
21	RX5+	Internally not connected
22	Clock shield	TMDS Shield for Clock
23	Clock+	TMDS Clock+ Input
24	Clock-	TMDS Clock- Input
C1	Analog Red	Internally not connected
C2	Analog Green	Internally not connected
C3	Analog Blue	Internally not connected
C4	Analog Hsync	Internally not connected
C5	Analog Ground	Internally not connected

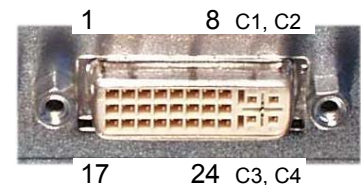

**First operation of a XCC-601 with DVI-Panel:**

The XCC-601 devices are preconfigured for a DVI-Panel with a resolution 640x480 (VGA). After power on the first time the XCC-601 detects the connected DVI-Panel by software and configures the device for the display. After this the device reboots automatically. The screen output is visible after the second boot. The display configuration will be done only the first time a DVI-Panel is connected or when a different DVI-Panel is connected (e.g. 800x600). The Start-Application (s.a. section 6.7) will be configured corresponding to the connected display as long as no customer project has been downloaded to the device.

If no DVI-Panel is connected the device starts with the default settings 640x480 (VGA). If a customer application is available on the device the resolution of this application will be used.

The visualization can than be operated remote via Web-Browser or via RemoteControl-Client (see visualization tool EPAM)

## 6 OPERATION

### 6.1 STARTUP BEHAVIOUR

After power on, the XVC/XCC-601 carries out a system test. The PLC does not switch to Run or Stop until no hardware errors have been found. The system test includes the following:

- Memory test
- Flash disk test
- Battery test

#### Start messages

After power on the following boot-messages will be displayed:

- IP-address of the device
- Version of the DP-interface (only for devices with Profibus-DP)
- State of the PLC-project
- State of the Retain-memory (Message if the Retain-memory will be erased)

### 6.2 SHUTDOWN BEHAVIOUR

Voltage dips of  $\leq 10\text{ms}$  at 24V (➔ Section 12) are bridged by the power supply unit. Longer voltage dips will cause the PLC to be reset automatically.

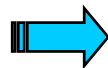

**Writing data to the CompactFlash™ during a power supply failure will cause the data to be lost!**  
The EPAM visualization software therefore makes a copy of the file in the directory C:\BACKUP before every write operation. These files are restored if necessary at the start.

### 6.3 PLC OPERATING STATES

#### Power on

In Power on status, there is no user program in the PLC. In this status it is possible to load a program onto the PLC. The Power on status is indicated in the programming software.

#### Stop (Stop-RESET)

The Stop operating status has the following features:

- A user program is stored on the PLC
- The user program is not running

“Stop” resets all variables to the value with which they were initialized apart from the retain variables (RETAIN, PERSISTENT). Variables that were not explicitly assigned an initialization value are set to standard initial values (e.g. integers set to 0). All outputs will be reset to 0.

The Stop status is selected:

- After power on, if the entry Startup=STOP has been made in the PLC.INI file (→ Section 6.7)
- After power on, if the entry Startup=AUTO has been made in the PLC.INI file (→ Section 6.7), and the PLC was in Stop status at the last online access via the programming software
- After power on, if the entry Startup=SWITCH has been made in the PLC.INI file (→ Section 6.7), and the operating mode switch (OMS) is in Stop-RESET position.
- Via the programming software in the PC (Online-Stop and –Reset)
- After the cycle time is exceeded

#### Run

In RUN status, the user program is processed cyclically.

The RUN operating status is selected:

- After power on, if the entry Startup=WARM has been made in the PLC.INI file (→ Section 6.7) (Default)
- After power on, if the entry Startup=SWITCH has been made in the PLC.INI file (→ Section 6.7), and the operating mode switch (OMS) is in RUN position.
- Via the programming software in the PC
- After power on, if the entry Startup=AUTO has been made in the PLC.INI file (→ Section 6.7), and the PLC was in Run status at the last online access via the programming software

#### System Fault SF

The following system faults can occur (→ Section 10):

- Hardware fault
- Firmware system faults

## 6.4 CHANGING OPERATING MODE

The operating mode of the XVC/XCC-601 devices is changed via the PLC.INI configuration file in the C:\MCONTROL directory on the CompactFlash™, via the programming software or via operating mode switch (OMS).

### PLC.INI configuration file:

The following entries can be made in the [BOOT] section:

Startup=WARM	...PLC starts in RUN mode (Default)
Startup=STOP	...PLC starts in STOP mode
Startup=AUTO	...PLC startup behaviour can be controlled by the programming software. The PLC starts up in the status set at the last online access.
Startup=SWITCH	...PLC starts corresponding to the position of the operating mode switch (OMS)

### Operating Mode Switch (OMS)

Position: Stop-RESET	...PLC starts in operating mode STOP
Position: RUN	...PLC starts in operating mode RUN

### Programming software

#### **Reset, Stop**

This commands resets all variables to the value with which they were initialized apart from the retain variables (RETAIN, PERSISTENT). Variables that were not explicitly assigned an initialization value are set to standard initial values (e.g. integers set to 0). All outputs will be reset to 0. XSoft outputs an appropriate safety prompt before all variables are overwritten. This also happens when there is a power failure or when the PLC is switched off and on again (warm start). Use the command 'Online', 'Start' to restart the PLC and resume program processing.

#### **Reset Cold**

This command resets all variables to their initial values regardless of whether they are RETAIN variables or not. Only persistent variables retain the value they had before the reset. All outputs will be reset to 0.

#### **Reset Original**

This command resets all variables including retain variables (RETAIN and PERSISTENT) to their initial values and deletes the user program on the PLC. The PLC is reset to its basic setting. All outputs will be reset to 0.

#### **Start**

The command starts the running of the user program in the PLC. The command can be executed directly after the commands 'Online', 'Load' or after the user program was stopped in the PLC via the commands 'Online', 'Stop', or if the user program is at a break point, or after the commands 'Online', 'Single Cycle'.

A detailed description of the online functions is also provided the XSoft manual.

**6.5 STARTUP BEHAVIOUR/STARTUP**

After power on, the user program is loaded from the CompactFlash™ into the RAM and the PLC is started.

**Procedure:**

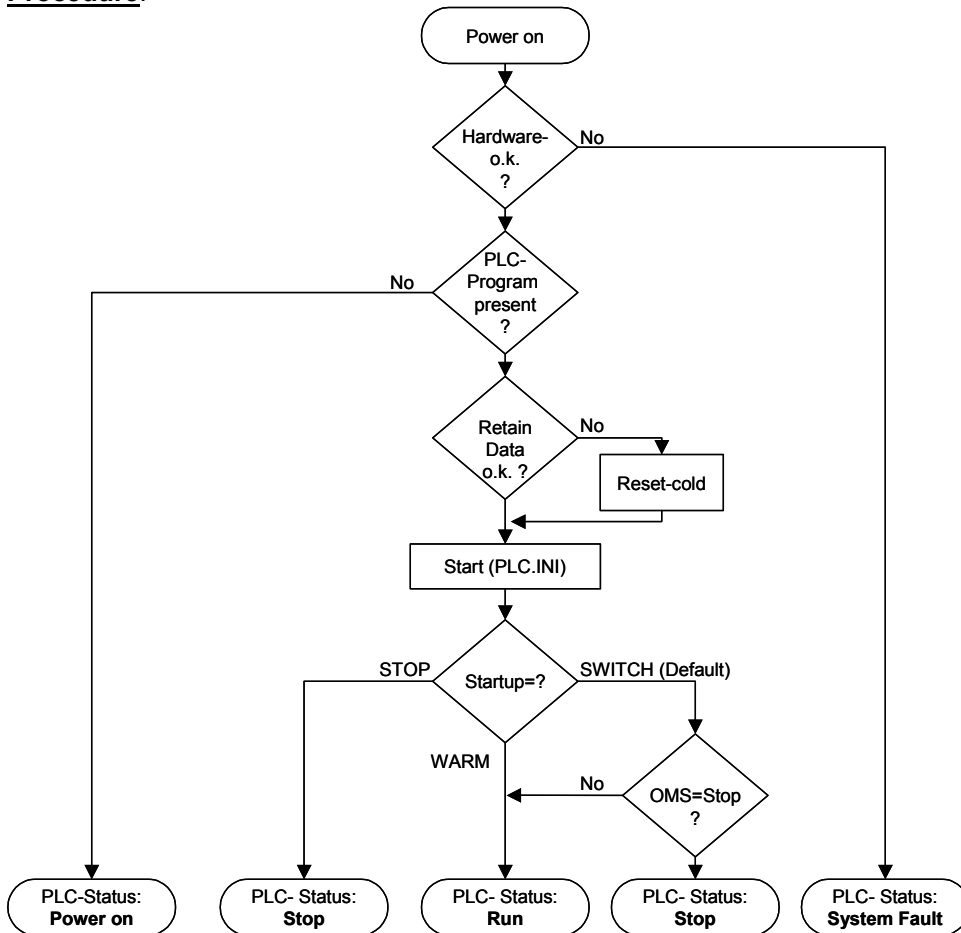

**6.6 PROGRAM TRANSFER**

If the user program was compiled error-free on the programming device (PC), it can be loaded into the working memory of the XVC/XCC-601 and then started.

**PC → PLC:**

When logging on to the PLC from the PC, the program in the PLC is compared to the program in the PC. If they are not the same, a prompt will ask whether the program is to be overwritten. If this prompt is confirmed, the PLC switches to Stop status and the new program is loaded into the working memory. (Program transfer/Online Change see also the XSoft manual).

**PC → PLC and CompactFlash™:**

The user program is saved on the CompactFlash™ by generating a boot project.

## 6.7 SYSTEM SETTINGS

The XVC/XCC-601 devices are supplied with a startup application that allows the following system settings:

- IP address setting (Default: 192.168.0.99)
- Subnet mask setting
- Gateway address setting
- Date and time setting
- Contrast and backlight setting
- Touch-screen calibration (resistive touch-screen only)
- Profibus DP Master/MPI or Slave configuration

For XVC-devices it is possible to change system settings via display and touch-screen. For XCC-devices it is necessary to connect a DVI-Panel (see accessories) or to use a Web-Browser with Web-EPAM.

These system settings must be made in the visualization application of the user. The start application is supplied with EPAM for this purpose, and can be used as a basis for user applications.

After a new project is downloaded, the start application is no longer available. The system settings can therefore only be carried out if this is implemented in the application.

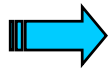

**The system settings must be implemented in the visualization application. After a new project is downloaded, the start application is no longer available! The IP settings are saved in the CONFIG.INI file.**

The subnetwork mask is defined automatically on the basis of the class of the IP address. For the default IP address the subnetwork mask is:  
255.255.255.0

**PLC.INI configuration file**

The PLC.INI file is supplied in the following state:

```

#*****
# PLC.INI
#
# Note: Preserving the original configuration is recommended
#
#*****

[BOOT]
Startup=WARM      # Startup-Mode of PLC-Bootproject: WARM (default) / STOP / AUTO / SWITCH
                  # Note: Startup-Mode AUTO preserves the PLC-Mode of the last Online-Session

[CONFIG]
RetainMode=CST_RETAIN_CYCLE  # Retain memory saved at end of PLC cycle (CST_RETAIN_CYCLE=default)
RetainSize=0x8000
RetainAddress=0xD8000

CAN
CANbaudrate=500      # Startup CAN baud rate (no used with XSoft CAN Configurator)
CANinQueueSize=16

[EPAM]
PrioEPAM=254        # Priority of EPAM task (254=default)
PrioTOUCH=253       # Priority of touch task (should be lower than PrioEPAM) (253=default)
DelayTicksEPAM=1    # Number of system ticks that EPAM suspends at the end of the EPAM loop (1=default)

```

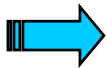

**Only the [BOOT] entry can be changed by the user in the PLC.INI configuration file. All other settings must not be changed.**

**6.8 BEHAVIOR OF THE PLC ON ERRORS**

<b>Error</b>	<b>Behavior of the PLC</b>
Watchdog (cycle time exceeded)	Stop
Integer-Division by zero	Stop
Floatingpoint-Division by zero	Wrong result, PLC is still running → <b>must be detected within the application!</b>

## 7 MOUNTING INSTRUCTIONS

### 7.1 GENERAL MOUNTING INSTRUCTIONS

All XVC-601 series devices are mounted from the front, i.e. in a control panel. They are fastened from the rear with the supplied fixing frame and 4 securing nuts.

All XCC-601 series devices are mounted in a control panel. They are fastened with 4 screws at the strapping in a control panel. The device should be mounted vertically with connectors on the lower side to allow air convection.

All XVC/XCC-601 series devices can be operated up to a maximum ambient temperature of 50°C (→ Section 12). The ambient temperature stated applies to the area in the direct vicinity of the lower connectors, if the device is mounted vertically with unimpeded air convection and a maximum operating height of 2000m above sea level.

The device can be mounted in an enclosure if the ambient temperature is taken into consideration. Provide a wall clearance of at least 50 mm on all sides of the housing, so that sufficient air circulation is ensured. A minimum clearance of 75 mm from active elements such as load current supply, transformers etc. must be ensured.

Avoid the exposure of the flat screen to direct sunlight. The radiation from the sun (UV component) reduces the lifespan of the LCD display.

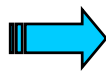

**The following must be ensured in order to prevent the device from overheating during operation:**

- **The cooling slots must always be free in order to ensure the proper cooling of the system.**
- **Avoid the exposure of the flat screen to direct sunlight.**
- **The mounting angle must not exceed  $\pm 35^\circ$  from the vertical**

**If these conditions cannot be met, the mounting of an external fan is recommended.**

### 7.2 MOUNTING IN THE FRONT PANEL - GENERAL

1. Push the XVC-601 from the front into the cutout (→ Section 7.4) of the front panel.
2. The front seal must be level and evenly positioned between the front plate and the front panel.
3. Centering the device in the cutout
4. Secure the device from the rear with the supplied fixing frame. For this use the 4 securing nuts which should be tightened evenly from the rear until the front frame is flush with the front panel all round.

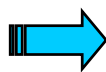

**Ensure that the seal is fitted correctly on the front panel. For devices with a round seal the two ends must be at the lower side of the device and should fit together without a gap.**

**Avoid tightening torques of greater than 0.5 Nm as this could otherwise damage the device.**

**The thickness of the front panel must not exceed 5 mm.**

### 7.3 MOUNTING IN THE FRONT PANEL – ATEX

All XVC-601 series devices are designed for use in machines and plants which are placed in hazard zone 22.



**The XVC-601 series devices fulfill the requirements for machines and plants which are placed in hazard zone 22 only, if they are mounted in enclosures or other devices which fulfill the requirements of ATEX standards.**

**Especially IP65 requirements must be fulfilled and the surface temperature must not exceed 80°C.**

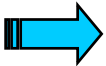

**For a save installation, operation and mounting please notice the mounting and type label instructions. (see section 7.2)**

**7.4 FRONT PANEL CUTOUT XVC-601 10,4''**



The device requires a mounting cutout of WxH:  
329 +0/-1 mm x 238 +0/-1 mm

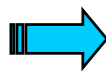

**The thickness of the front panel must not exceed 5 mm.**

**Recommended Mounting versions for Laser cutout (device centering)**

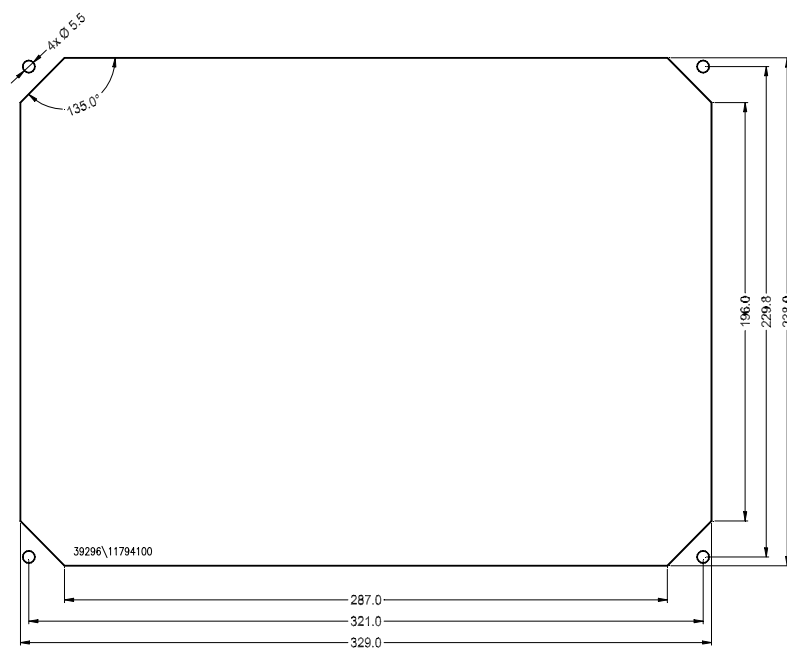

**7.5 FRONT PANEL CUTOUT XVC-601 12,1"**



The device requires a mounting cutout of WxH:  
344 +0/-1 mm x 262 +0/-1 mm

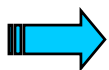

**The thickness of the front panel must not exceed 5 mm.**

**Recommended Mounting versions for Laser cutout (device centering)**

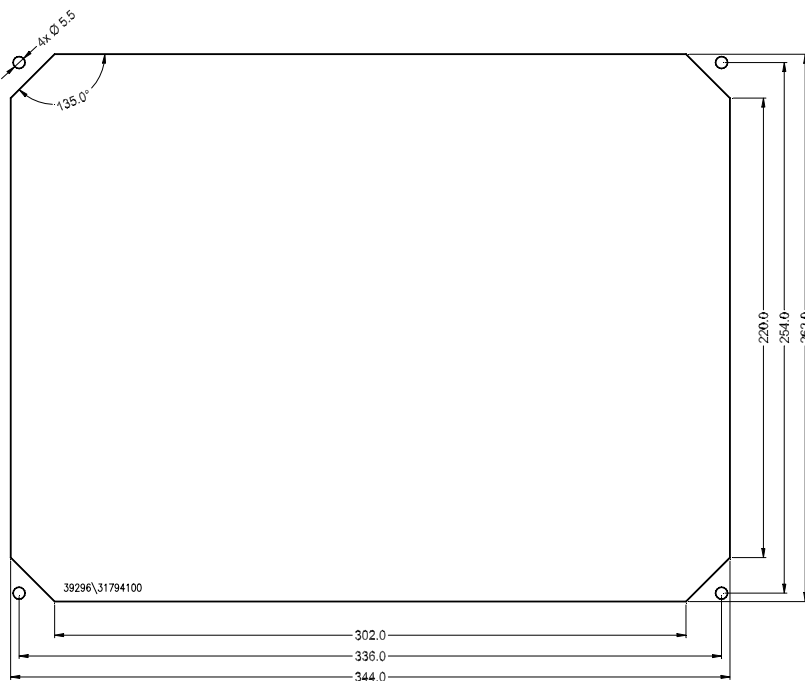

**7.6 FRONT PANEL CUTOUT XVC-601 15"**

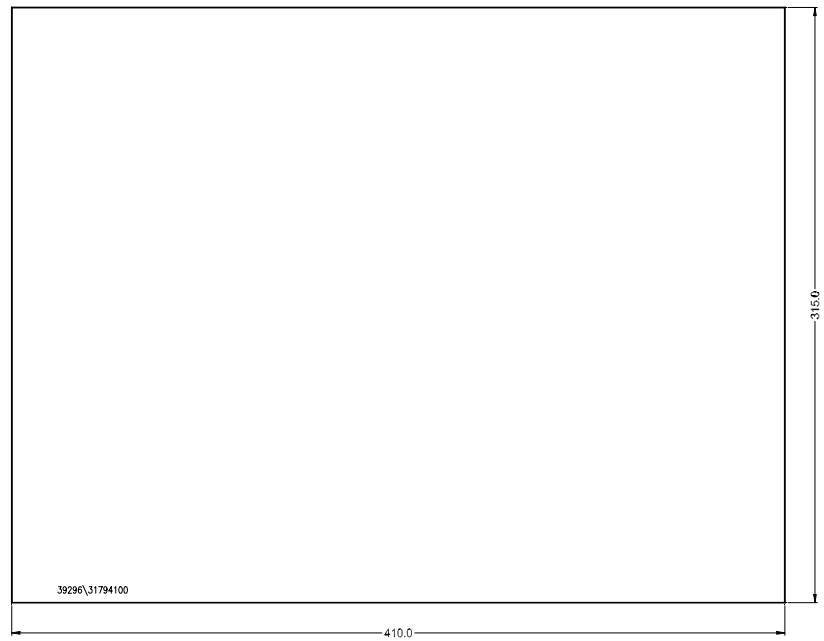

The device requires a mounting cutout of WxH:  
410 +0/-1 mm x 315 +0/-1 mm

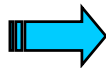

**The thickness of the front panel must not exceed 5 mm.**

**Recommended Mounting versions for Laser cutout (device centering)**

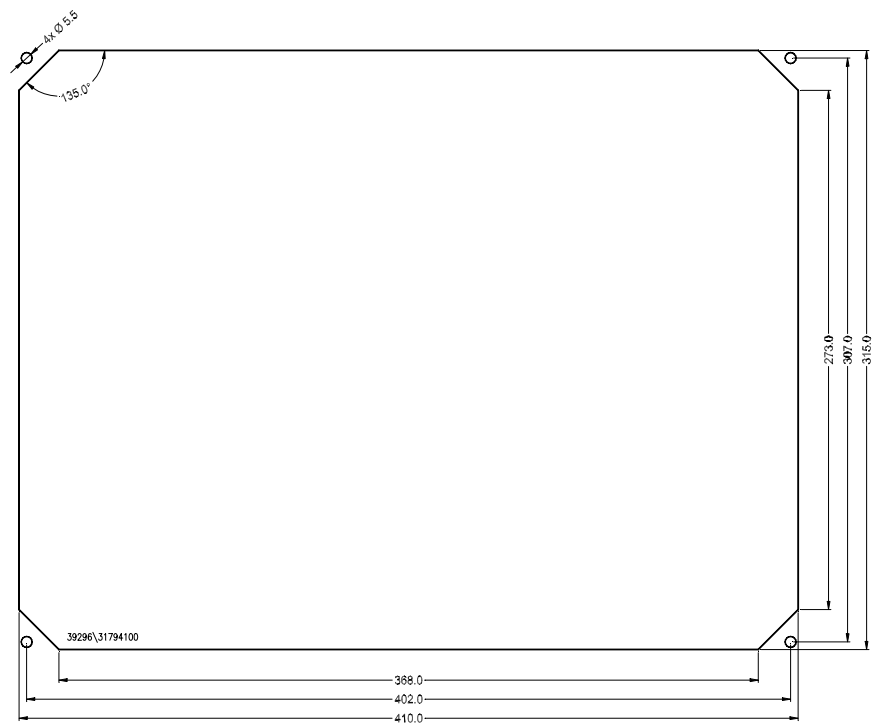

**7.7 MECHANICAL DIMENSIONS XVC-601 10,4"**

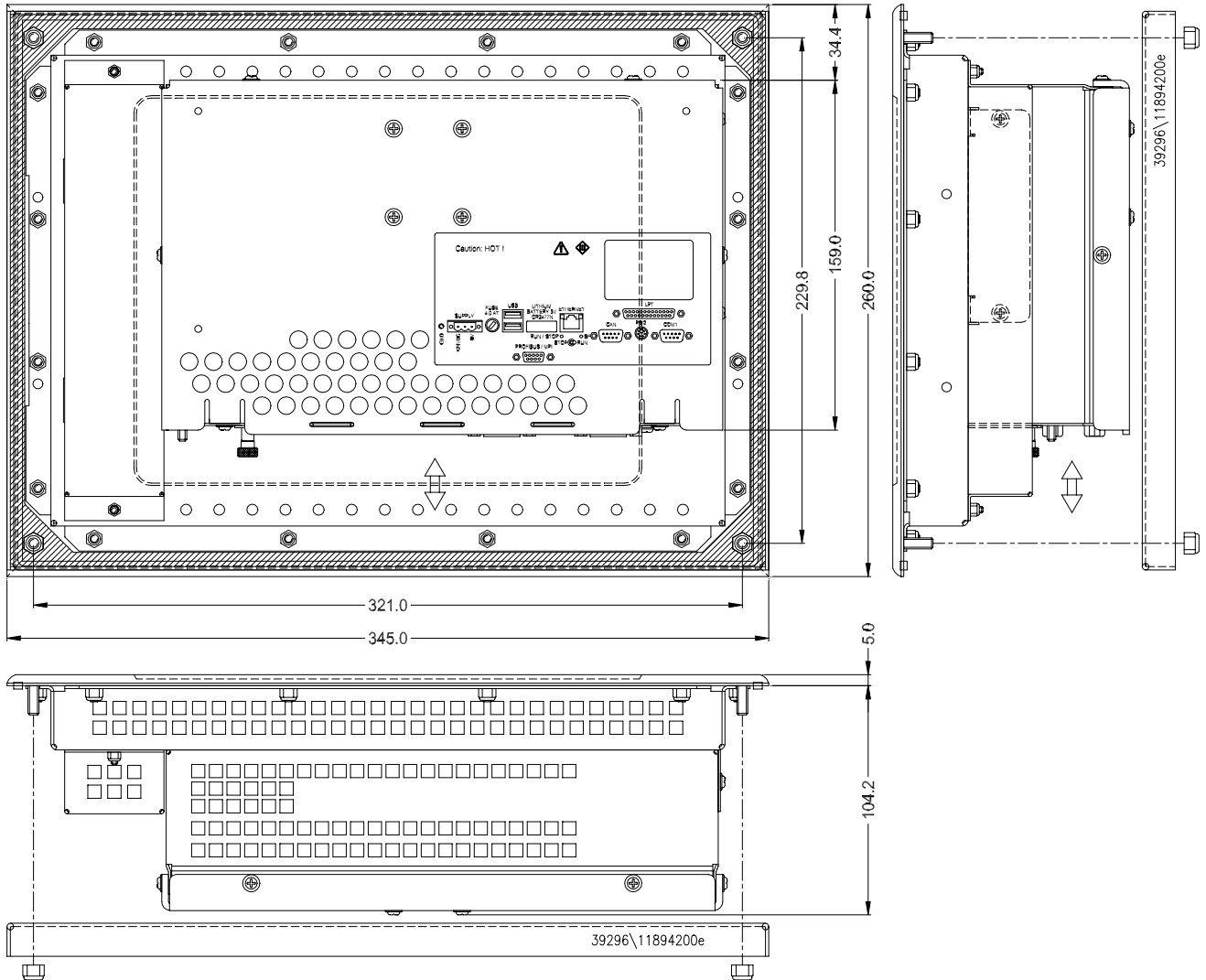

7.8 MECHANICAL DIMENSIONS XVC-601 12,1"

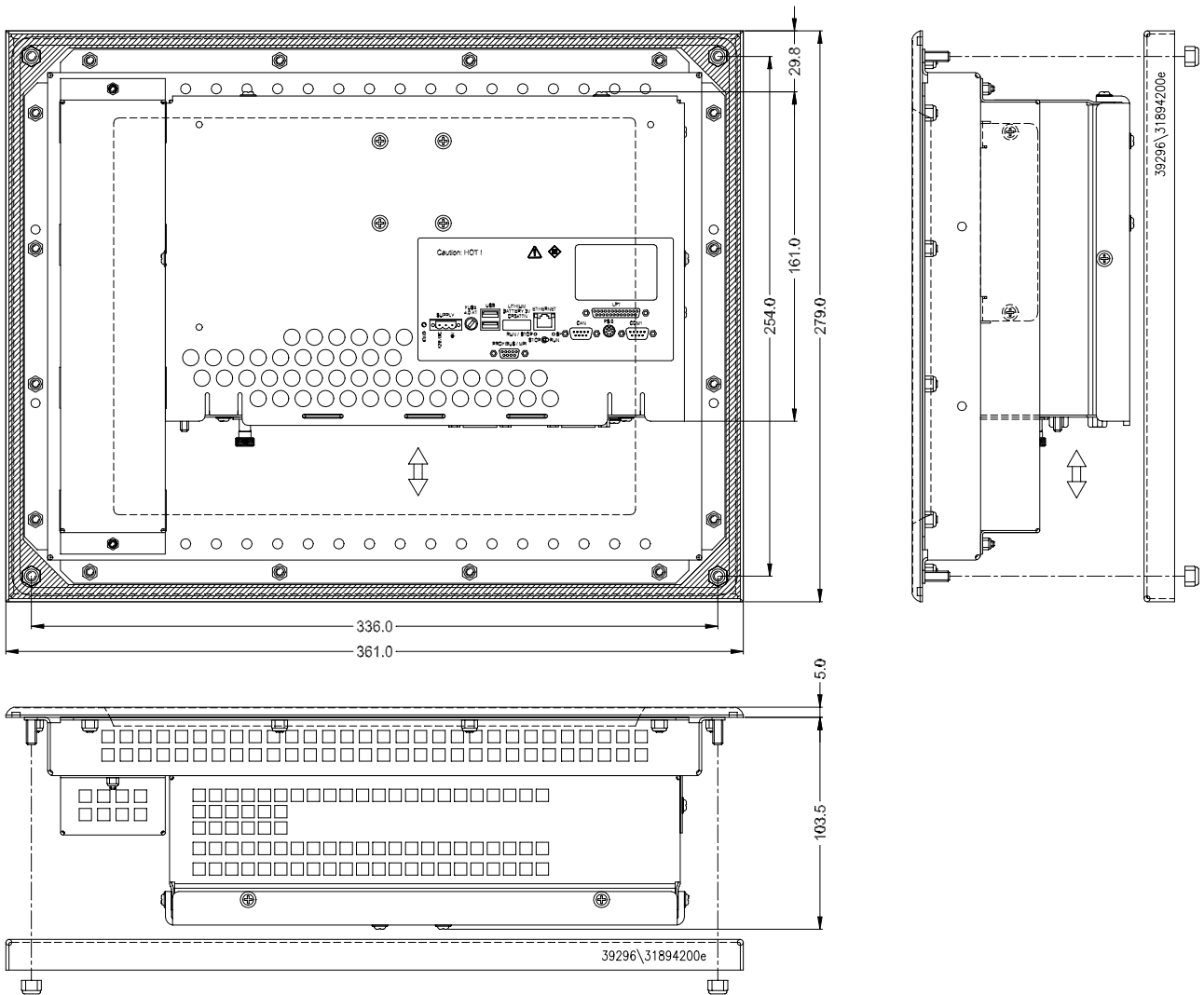

**7.9 MECHANICAL DIMENSIONS XVC-601 15"**

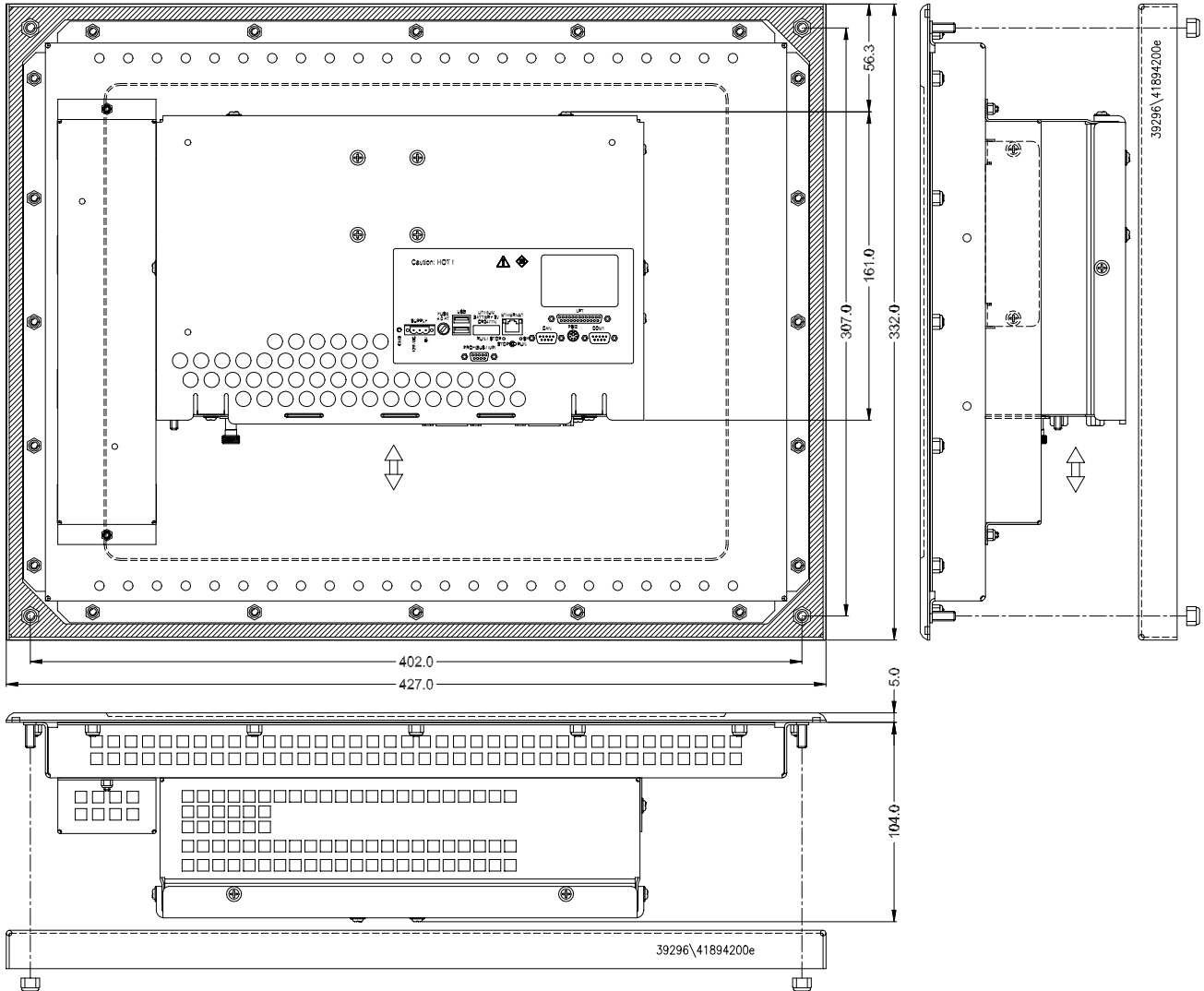

7.10 MECHANICAL DIMENSIONS XCC-601

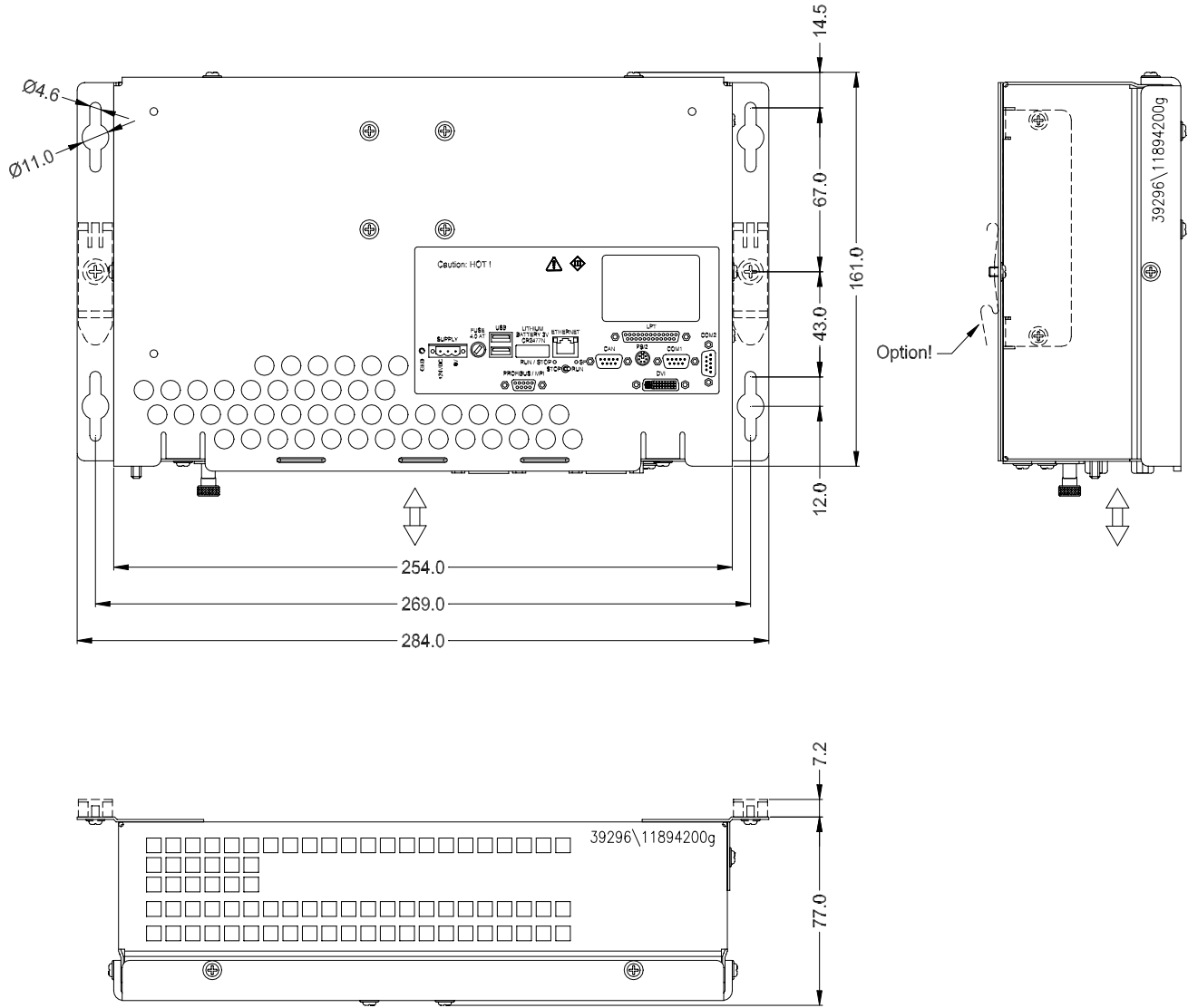



## 8 NOTES ON THE TOUCH-SCREEN

### 8.1 BASIC TOUCH-SCREEN FUNCTION

#### **Devices with infrared touch-screen**

The touch-screen operates on the active light matrix principle in the infra-red range. Interrupting this light matrix at any point will initiate an operation if a touch activated screen element was touched (e.g. a button).

A timeout is initiated if the light matrix is interrupted for longer than **approx. 15s**. The touch panel then switches to the “non-actuated” state, and further operations cannot be initiated until the initial touch actuation has stopped (e.g. button released) or the touch is actuated again. Several simultaneous touch actuations at different points cannot be evaluated.

#### **Devices with resistive touch-screen**

The resistive touch-screen operates on an analog principle. Pressing the touch-screen at any point results in an electrical resistance which is measured and will be calculated into a position by the touch controller. This initiates an operation if a touch activated screen element was touched (e.g. a button).

Because of this function principle the resistive touch-screen has to be calibrated. The first calibration is already done when delivered. A recalibration of the touch-screen is necessary when the touch position is different to the screen, e.g. because of ageing, temperature, etc. The calibration can be activated within an EPAM project (see EPAM manual, Button-Action „Touch\_calibrate”).

It is also possible to start the touch-screen calibration by pressing the touch-screen during power on. In this case the message “Performing touch calibration” appears. After pressing the touch-screen until the device beeps 5 times in this mode the touch-screen calibration will be started after releasing the touch-screen.

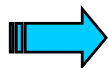

**For an optimal operation of the touch-screen it is recommended to use a touch-pen for the calibration.**

## 8.2 POWER UP FUNCTION TEST

### Devices with infrared touch-screen

The XVC/XCC-601 carries out a function test of the touch-screen with each power up of the device (XCC only if a DVI-Panel is connected). All IR channels are tested during this stage. Faulty IR channels are indicated graphically and displayed on screen with an error message. The failure of IR channels is normally due to severe contamination of the IR transparent plastic frame which consequently has to be cleaned (➔ Section 8.3). The optical elements of the light matrix are located behind the IR transparent plastic frame in the front of the device.

IR channels that are continuously interrupted will be detected by the touch controller after a timeout of approx. 15s and no longer included in the evaluation. In extreme cases, this may mean that individual zones cannot be touch activated.

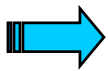

**Do not touch the screen whilst the system is being started up, and wait till your application has started.  
During the startup the touch screen carries out a function test.**

### Devices with resistive touch-screen

Because of function principle it is not possible to do a function test on devices with resistive touch-screen.

### 8.3 CLEANING AND MAINTENANCE OF THE TOUCH-SCREEN

#### **Cleaning of infrared touch-screen**

For operation ensure that the signal levels of the channels are not so severely reduced or interrupted due to excessive contamination through dirt (→ Section 8.1).

Clean the black plastic frame at the front of the device front regularly (→ Section 11) with a damp soft cloth. Ensure that the surface is not scratched or scoured, especially when removing hard deposits and abrasive dust.

Do not expose the front of the device to solvents which may corrode and loosen the plastic frame (frame material: Makrolon 2805, Manufacturer: Bayer AG).

#### **Cleaning of resistive touch-screen**

Do not expose the front of the device to solvents which may corrode and loosen the plastic membrane (material: Polyester). Ensure that the surface is not scratched or scoured, especially when removing hard deposits and abrasive dust.

**Cleaning should only be carried out with the device switched off!** This will ensure that any touching of the screen will not accidentally initiate functions.



**Please use a soft cloth to ensure that the surface is not scratched or scoured. Do not use solvents.**



## 9 DISPLAY, BACKLIGHT, CONTRAST

### 9.1 CONTRAST

The XVC-601 series are delivered with TFT displays. This displays require no contrast settings (only necessary for passive LCD displays).

### 9.2 BACKLIGHT

The backlight has two settings low (50%) and high (100%) which can be selected in the EPAM visualization software.

## 10 DIAGNOSTICS

The following optical and acoustic diagnostic options are available:

Symptom	Possible cause and solution
Signal on power on	Acoustic signal: 2x short → Touch controller OK
Device does not start, screen dark or error messages during startup	- Check power supply/fuse faulty - Drive not ready → CompactFlash™ with XVC/XCC-601 runtime system not inserted (→ Section 5.2).
Date/time incorrect	- Battery empty, replace battery (→ Section 11)
Screen dark or light	- Backlight/contrast incorrectly set → Reload EPAM project with Delete INI Files option
Touch-screen not functioning	- Hardware faulty (no acoustic signal after power on) - Too many IR channels interrupted → Clean touch-screen (infrared touch-screen only) - The touch-cable was removed and reconnected after power up (only XCC) → restart the system
Ethernet connection faulty	- Incorrect Ethernet cable fitted (crosslink/direct). → The LINK LED is lit when the connection is correct → The ACT LED is lit (flashing during transfer) with a correct data transfer - Incorrect/invalid IP address set → the current IP address is shown during startup
RUN-LED	- RUN-LED on: PLC-program is loaded an running
Profibus-ERR (LED red)	ON → Profibus error OFF → no error
Profibus-STA (LED yellow)	ON → Profibus DP-Master: send data or token → Profibus DP-Slave: Data exchange with Master OFF → no token

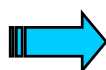

Refer to the XSoft engineering software for other diagnostics options.



## 11 MAINTENANCE AND REPAIR

### Cleaning the screen

For trouble-free operation of the IR touch-screen, clean the inner section of the device front (front glass and IR frame) regularly (➔ Section 8.3).

### Battery

The battery is used for backing up the real-time clock. The battery should be changed every 5 years in order to prevent any data loss of date and time. The battery can be removed during operation.

Procedure for changing the battery

1. pull out the battery with the shackle
2. Replace battery

### Repairs

Repairs to the XVC/XCC-601 should only be carried out by the manufacturer or Moeller GmbH repair centers. In this case, please contact your local XSystem dealer or the Technical Support at Moeller GmbH. (manufacturer address of XVC/XCC-601 ➔ Section 14)

No liability is accepted for any modifications made to the device that are not described in this document.

### Transport

Only the original packaging must be used for transporting the device. The climatic conditions (➔ Section 12) has to be observed.

### Storage

The device has to be stored under the conditions specified in Section 12. Please be aware, that a high storage temperature reduces the lifetime of the real-time-clock battery. A permanent storage at 70°C reduces the lifetime of the battery to about 3 years.

It is recommended to store the device at room temperature.



**12 TECHNICAL DATA**

<b>Display</b>	Technology	10,4" / 12,1" / 15" TFT LCD	
	Resolution	10,4": 12,1": 15":	VGA 640 x 480 SVGA 800 x 600 XGA 1024 x 768
	Number of colors	256k colors	
	Display area	10,4": 12,1": 15":	211 x 158 mm 246 x 185 mm 304 x 228 mm
	Backlight	1	CCFL, dimmable via software 2 x CCFL (50000h), contrast ratio: 250:1 brightness: 400cd/m <sup>2</sup> 4 x CCFL (50000h), contrast ratio: 500:1 brightness: 500cd/m <sup>2</sup> 2 x CCFL (35000h), contrast ratio: 300:1 brightness: 250cd/m <sup>2</sup>
	0,4":		
	12,1":		
	15":		
	Front plate	Infrared touch-screen: Safety glass, non-reflective Resistive touch-screen: Polyester/glass laminate	
<b>Operation</b>	Type	Infrared or resistive touch-screen	
	Resolution	10,4": 12,1": 15":	Infrared touch-screen 81 x 61 93 x 71 115 x 87
		Resistive touch-screen: 12 Bit analog (0-4096)	
<b>Ambient conditions</b>	Operating climate	Class 3K3 EN50178 (advanced/reduced) 0..50°C vertical installation 0..40°C tilted installation max. 35° 10...90% rel. air humidity, non-condensing	
	Storage climate	Class 1K4 EN50178 (reduced) -20...60°C, 10...90% rel. air humidity, non-condensing	
	Transport climate	Class 2K3 EN50178 (reduced) -20...60°C, 10...90% rel. air humidity, non-condensing	
	Vibration	<60Hz: 3.5mm >60Hz: 1g	EN60068-2-6 EN60068-2-6
	Shock	15g / 11ms EN60068-2-27	
	EMC interference immunity	Industrial 4kV / 8 kV 10V/m 2kV 0.5kV / 0.5kV 10Vrms	EN 61000-6-2 EN 61000-4-2 EN 61000-4-3 EN 61000-4-4 EN 61000-4-5 EN 61000-4-6
	Emission	Residential EN 61000-6-3	
<b>Degree of protection</b>	Front	EX II 3D T80°C X, 0°C < T <sub>amb</sub> < 50°C IP 65 (NEMA 12), after EN 60068-2-68 → note section 7.2 and 7.3!	
	Rear	IP 20	
<b>Weight</b>		XCC-601: 10,4": 12,1": 15":	Approx. 2,0kg Approx. 5,3kg Approx. 5,8kg Approx. 6,9kg

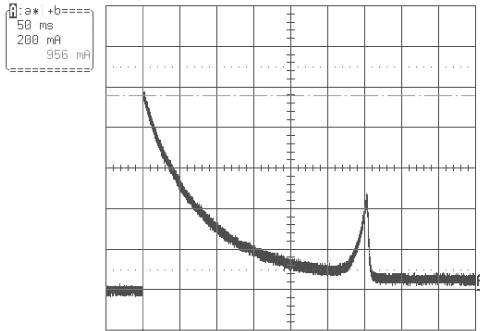
<b>Dimensions</b>	W x H x D	XCC-601 : 284 x 170 x 77 mm 10,4": 345 x 260 x 100 mm 12,1": 361 x 279 x 100 mm 15": 427 x 332 x 100 mm
	Cutout 10,4": 12,1": 15":	329 x 238 mm (+0/-1mm) 344 x 262 mm (+0/-1mm) 410 x 315 mm (+0/-1mm) see mounting instructions!
<b>System supply</b>	Rated voltage	24 VDC SELV, safety extra low voltage, protection class III
	Voltage range	24 VDC to DIN 19240 20.4...28.8 VDC effective, absolute value with ripple 18.5...30.2 VDC 35.0 VDC for a duration of < 100ms
	Voltage dips	10 ms EN61000-6-2
	Protection against reverse polarity	Yes
	Fuse protection	Yes
	Potential isolation	No
	Current consumption	Normally at 24VDC XCC-601: 0.6A 10,4": 1.0A 12,1": 1.1A 15": 1.4A
Power consumption	Normally XCC-601: 14.4W 10,4": 24.0W 12,1": 26.4W 15": 33.6W	
Power on rush-in current	at 24VDC: 1A initial-current peak typically at 30VDC: 1.25A initial- current peak typically 30-Mar-04 11:52:14  50 ms B1A1 Minimal power off time: 5s	
<b>Battery backup</b>	Battery type	3V / 950mAh Lithium, RENATA CR2477N
	Data retention	Normally 5 years
<b>Real-time clock</b>	Counters	Seconds, minutes, hour, day, month, year
	Leap year change	Automatic
	DST change	Manual via the software
	Deviation at T <sub>amb</sub> =25°C	Typ. +/- 100ppm
<b>Fuse protection</b>	Fuse	4 A slow
	Breaking capacity	Max. 40A
<b>Programming interface</b>	Type	Ethernet
	Connection	RJ45

<b>Interfaces</b>		
<b>COM1</b>	Type	RS232, not isolated
	Connection	CiA, Sub-D 9-pole male
<b>COM2</b>	Type	RS232, not isolated
	Connection	XVC: internally used for touch-screen XCC: CiA, Sub-D 9-pole male Attention! 12VDC at Pin 4 and 9
<b>LPT1</b>	Type	Centronix, not isolated
	Connection	D-Sub 25pole female
<b>CAN</b>	Type	CAN, isolated
	Connection	CiA, Sub-D 9-pole male
<b>ProfibusDP (Option)</b>	Type	Master/slave to 12MBit
	Connection	Sub-D 9 pole female
<b>Ethernet</b>	Type	10/100BaseT
	Connection	RJ45
<b>Keyboard</b>	Type	Standard AT (only for service tasks)
	Connection	PS2
<b>CompactFlash™ Slot</b>	CompactFlash Type II	
	Technology	ATA Flash, 5V MicroDrive™
<b>Noise emission</b>	<70dB	



## 13 DISPOSAL

XVC/XCC-601 devices that are no longer used must be disposed of properly or returned to the manufacturer for disposal. (manufacturer's address → Section 14)

### Special note:

- The device contains a lithium battery
- LCD units are fitted with fluorescent tubes for the backlight. These contain mercury.

### Materials:

Housing:	Galvanized sheet steel
Rear:	Aluminium coated
Front frame:	Aluminium, anodised
Membrane:	Polyester PETP
Printed-circuit board:	1. quality
Front:	IR touch-screen: Safety glass, Plastic frame Makrolon 2805 (Manufacturer: Bayer AG)

Resistive touch-screen:  
Polyester/glass laminate

## 14 EU CONFORMITY AND STANDARDS

The XVC/XCC-601 meets the requirements specified by the EU Council Directives for harmonizing the regulations of EU member states relating to electromagnetic compatibility (**89/336/EEC**).

The generic standards below were used to assess the electromagnetic compatibility of the XVC/XCC-601:

**EN 61000-6-3** (Emission)

**EN 61000-6-2** (Immunity)



The following standard was used to assess the functionality of the XVC/XCC-601:

**EN 61131-2**

The following standard was used to assess the electrical safety of the XVC/XCC-601:

**EN 50178**

All XVC-601 series devices are designed for use in machines and plants which are placed in hazard zone 22. (see section 7.2 and 7.3)

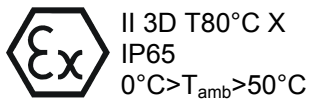

All XVC/XCC-601 are compliant to:

**UL 508 - Industrial Control Equipment.**

**cUL (CSA 22.2 No. 14-M95)**



Ind. Cont. Eq.  
19CC

Manufacturer: Moeller GmbH

Manufacturer address: Hein-Moeller-Str. 7-11  
D-53115 Bonn  
Germany

**15 REVISION HISTORY**

Revision	Date / Signed	Modifications
1.0	04-04 / Fis	First version for XVC/XCC-601
2.0	06-04 / Fis	P.18 sentence "The fuse must be changed..." removed P.25 pin assignment corrected P.26 analog Outputs P.35-37: Mounting versions for Laser cutout P.51: EMV 2kV P.52: protection class III, minimal power off time P.56: Note Low voltage directive removed
3.0	06-04 / Fis	P.24 pin assignment corrected P.51 XCC dimensions corrected AWB number corrected
4.0	11-04 / Fis	New behavior of RTS-V1.34 and newer: P.27 Start messages corrected P.28 Stop makes also a Reset P.29 Reset resets outputs P.30 Startup = Switch (Default) P.32 Behavior on errors P.47 Display of the IP-address corrected
5.0	12-04 / Fis	P.11 Text „In preparation“ removed (res. DVI-Panel) P.56 UL-Conformity
6.0	05-05 / Fis	P.9,10 DPS version removed P.15 Profibus-LED P.24,31,47 Profibus DP configuration P.56 CSA- Conformity
7.0	12-05 / EP, Fis	P.24 5V max. 10mA, table with device index P.25 Power Supply on COM2 clarified P.31 Setup of Subnet-mask P.47 More Diagnostics for XCC added

**Moeller GmbH**  
**Hein-Moeller-Str. 7-11**  
**D-53115 Bonn**  
**Germany**

**Tel** : **+49(0) 228/602-0**  
**Fax** : **+49(0) 228/602-2433**  
**email** : **automation@moeller.net**  
**homepage** : **www.moeller.net**



## 16 ALPHABETICAL INDEX

<b>A</b>		
Accessories .....	11	
Ambient conditions .....	51	
Application range .....	7	
<b>B</b>		
Backlight .....	47	
Basic touch-screen function .....	43	
Battery .....	49	
Battery type .....	52	
Behavior of the PLC on Errors .....	32	
<b>C</b>		
CAN .....	53	
CAN connector .....	15, 21	
CAN interface .....	21	
Cleaning .....	45	
Cleaning and maintenance of the touch-screen .....	45	
Cleaning the screen .....	49	
COM1 .....	53	
COM2 .....	15, 53	
Commissioning .....	15	
Communication .....	13	
CompactFlash .....	15, 53	
Connecting a DVI-Panel to a XCC-601 .....	26	
Connecting the power supply .....	18	
Connecting the programming interface .....	20	
Connection for COM2 serial interface (RS232) .....	25	
Connection for keyboard .....	24	
Contents .....	3	
Contrast .....	47	
Copyright .....	2	
Cycle time .....	13	
<b>D</b>		
Danger warnings .....	5	
Degree of protection .....	51	
Designing .....	11	
Device versions .....	9	
Diagnostics .....	47	
Dimensions .....	52	
Display .....	13, 51	
Display, backlight, contrast .....	47	
Disposal .....	55	
<b>E</b>		
Email .....	57	
Ethernet .....	15, 53	
EU Conformity and Standards .....	56	
Exchangeable memory .....	13	
Explanation of symbols .....	5	
<b>F</b>		
Fax .....	57	
Features .....	13	
Front panel cutout 10,4" .....	35	
Front panel cutout 12,1" .....	36	
Front panel cutout 15" .....	37	
Front plate versions .....	9	
Fuse .....	15	
Fuse protection .....	52	
<b>H</b>		
Harddisk .....	15	
Homepage .....	57	
<b>I</b>		
Inserting the battery .....	17	
Inserting the CompactFlash .....	16	
Introduction .....	7	
<b>K</b>		
Keyboard .....	15, 53	
<b>L</b>		
Line Out .....	15	
<b>M</b>		
Maintenance and repair .....	49	
Manufacturer .....	56, 57	
Mechanical dimensions .....	38	
Mechanical dimensions 12,1" .....	39	
Mechanical dimensions 15" .....	40	
Mechanical dimensions XCC-601 .....	41	
Minimum clearance .....	33	
Mounting in the front panel – ATEX .....	34	
Mounting in the front panel - General .....	33	
Mounting versions for Laser cutout .....	35, 36, 37	
<b>N</b>		
Notes on the touch-screen .....	43	
<b>O</b>		
Operation .....	27	
Overview of connections .....	15	
<b>P</b>		
PLC operating states .....	28	
Power on .....	28	
Run .....	28	
Stop .....	28	
System fault .....	28	
Power supply .....	15	
Power up function test .....	44	
Preparing the shield connections .....	19	
ProfibusDP .....	53	
ProfibusDP interface .....	24	
Program transfer .....	30	
Programming cable .....	11	
Proper use .....	1	
<b>R</b>		
Real-time clock .....	52	
Repairs .....	49	
Reset .....	29	

Reset Cold.....29  
Reset Original.....29  
Revision history.....57  
RS232.....15

**S**

Safety instructions for the user.....2  
Scope of delivery.....10  
Shutdown behaviour.....27  
Start.....29  
Start messages.....27  
Startup behaviour.....27  
Startup behaviour/startup.....30  
Storage.....49  
System supply.....52

**T**

Technical data.....51  
Telefon.....57  
Touch.....13  
touch-screen calibration.....43  
Transport.....49

**U**

USB.....15

**V**

Visualization.....13

**W**

Warnings.....5  
Weight.....51

